

\$120 flat
34150-100
46100
40

RECORDED IN OFFICIAL RECORDS
INSTRUMENT # 2004193126 40 PGS
2004 OCT 06 04:17 PM
KAREN E. RUSHING
CLERK OF THE CIRCUIT COURT
SARASOTA COUNTY, FLORIDA
CBETHEL Receipt#533116

DECLARATION OF CONDOMINIUM

of

**SOUTH PRESERVE I AT WATERSIDE VILLAGE
a Condominium**



TABLE OF CONTENTS

<u>Paragraph</u>	<u>Subject Heading</u>	<u>Page</u>
	Table of Contents	
1	The Condominium Act	1
2	Name	1
3	Condominium Plat	1
4	Ownership of Common Elements and Sharing Common Expenses	2
5	Common Elements	2
6	Limited Common Elements	3
7	Association	3
8	Voting Rights	4
9	Common Expenses	4
10	Maintenance, Repair and Replacement	5
11	Insurance, Destruction and Reconstruction	6
12	Liability Insurance	9
13	Restrictions Upon Use	9
14	Sale, Transfer, Lease or Occupation of Unit	11
15	Assessments and Liens	12
16	Rights of Institutional First Mortgagees	12
17	Rights of Developer	13
18	Easements	13
19	Phased Development	14
20	Venice Center	16
21	Remedies For Default	17
22	Amendments	18
23	Termination	19
24	No Time Sharing	19
25	Binding Effect	19
26	Severability	19
	Joinder of Association	
	Exhibit "A" Condominium Plat	
	Exhibit "B" Association Charter	
	Exhibit "C" Bylaws	

RETURN TO: WILLIAM M. SEIDER, ESQ. ✓
WILLIAMS, PARKER, HARRISON,
DIETZ & GETZEN P.A.
200 SOUTH ORANGE AVENUE
SARASOTA, FLORIDA 34236

DECLARATION OF CONDOMINIUM

of

**SOUTH PRESERVE I AT WATERSIDE VILLAGE
a Condominium**

KNOW ALL MEN BY THESE PRESENTS, that Waterside Preserve, Inc., a Florida corporation ("Developer"), does hereby submit to condominium ownership pursuant to Chapter 718, Florida Statutes, 2002 the following described land and improvements thereon and all improvements hereafter erected thereon, situate, lying and being in the County of Sarasota, State of Florida, to-wit:

See legal description of Phase 1 of SOUTH PRESERVE I AT WATERSIDE VILLAGE set forth on the condominium plat attached hereto as Exhibit "A" and by this reference made a part hereof.

and that said property shall hereafter be subject to the following provisions, restrictions, reservations, covenants, conditions and easements:

1. **THE CONDOMINIUM ACT.** Chapter 718, Florida Statutes, 2002, known as the "condominium act," is incorporated herein by reference and all provisions thereof shall apply to this condominium, provided that the terms and provisions of this declaration shall control to the extent the statute authorizes a variance by the terms of a declaration of condominium or other condominium documents.

2. **NAME.** The name by which this condominium shall be known and identified is SOUTH PRESERVE I AT WATERSIDE VILLAGE, a condominium.

3. **CONDOMINIUM PLAT.** A survey of said land and plot plan locating the improvements thereon and identifying each condominium unit and the common elements and their relative locations and approximate dimensions (herein called "condominium plat") is attached hereto as Exhibit "A" and is recorded in Condominium Book 37 at pages 17-17 Public Records of Sarasota County, Florida. The locations, dimensions, descriptions, identification and numbering or lettering of the respective condominium units shall be described in the condominium plat and any subsequent amendments thereto as hereinafter provided. A unit shall consist of the space defined in the condominium plat. In the event the actual physical location of any unit at any time does not precisely coincide with the condominium plat and subsequent amendments, the actual physical locations shall control over the locations, dimensions and descriptions contained in the

condominium plat and subsequent amendments. In the event of a total or substantial destruction of any building, the locations, dimensions and descriptions of the respective units as contained in the condominium plat and subsequent amendments will control.

4. OWNERSHIP OF COMMON ELEMENTS AND SHARING COMMON EXPENSES. Each unit in the condominium shall have an equal share in the ownership of the common elements and common surplus and in the sharing of the common expenses of the condominium. Stated as a fraction, after the submission of the initial phase each unit's share initially shall be 1/12. If additional units are added to the condominium by the submission of additional phases to condominium ownership, the share of each unit will be adjusted to equal a fraction whose numerator is 1 and whose denominator is the total number of units then comprising the condominium.

5. COMMON ELEMENTS. Any right, title or interest in a condominium unit shall automatically carry with it as an appurtenance and without the necessity of specific reference thereto, its respective undivided share of the common elements and a right to use the common elements in conjunction with the owners of the other condominium units. The common elements shall include but not be limited to:

- (a) all of the above described land and all easements appurtenant thereto;
- (b) all improvements and parts thereof which are not included within the boundaries of the respective condominium units;
- (c) utility areas and installations and all utility services which are available to more than one unit or to the common elements and which are not owned by the respective utility companies, including easements through the units necessary to provide such services;
- (d) all parking areas, driveways, and other means of ingress and egress;
- (e) all electrical apparatus and wiring, plumbing pipes and apparatus, and other ducts, conduits, cables, wire or pipe, within the common elements and up to the exterior surface of the unit wall which are not owned by utility companies;
- (f) all tangible personal property required for the maintenance and operation of the condominium and for the common use and enjoyment of the unit owners;
- (g) all structural beams, posts and members within a unit and an easement of support in any portion of a unit which contributes to the support of the building;
- (h) alterations, additions and further improvements to the common elements;
- (i) all lands added to the condominium in subsequent phases pursuant to the provisions of paragraph 19; and
- (j) any lands owned by the Association and submitted to condominium ownership by an amendment to this Declaration approved and executed as provided

herein for amendments generally, pursuant to the provisions of Section 718.110(6), Florida Statutes.

The unit owners in the aggregate shall be entitled to equal and full use and enjoyment of all the common elements (except limited common elements) except as they may be restricted by the reasonable and uniform regulations duly adopted by the Association board of directors, which usage shall always be in recognition of the mutual rights and responsibilities of each of the unit owners.

6. LIMITED COMMON ELEMENTS. The following shall be deemed to be Limited Common Elements (LCE), the use of which shall be limited to those unit owners to whom such use is assigned by the Developer or by the Association:

(a) A unit may be assigned the exclusive use of a carport, together with adjacent storage area, for that unit's exclusive use. The carport shall be used solely for the parking of a private passenger vehicle. The assignment of a carport and adjacent storage area shall be made by painting or affixing the unit number upon the carport. Upon such assignment, the carport and storage area so assigned shall be deemed to be a Limited Common Element and the unit owner shall have the exclusive right to the use thereof without additional charge therefor by the Association other than such unit's normal share of the common expenses of the condominium. After such assignment is made, the exclusive right of the owner of such unit to use such carport and storage area shall become an appurtenance to said unit and shall be encumbered or conveyed thereafter as an appurtenance to the unit without necessity of specific reference thereto. After such assignment, such exclusive right may not be separately conveyed, assigned or encumbered, without the express written consent of the Association.

(b) Stairways and all heating and air conditioning equipment serving a unit or units and located outside of the unit are limited common elements for the exclusive use of the owner or owners of the unit or units served and to which they shall be appurtenant. A lanai, balcony, deck or porch which is not included within a unit boundary but which is contiguous to the unit shall be a limited common element for said unit.

7. ASSOCIATION. The corporation which will be responsible for the operation of the condominium will be an incorporated association known as SOUTH PRESERVE I AT WATERSIDE VILLAGE ASSOCIATION, INC., a Florida nonprofit corporation (the "Association"). All persons owning a vested present interest in the fee title to any of the condominium units as evidenced by a proper instrument duly recorded in the public records of Sarasota County, shall automatically be members of the Association and their respective

memberships shall terminate as their vested interest in the fee title terminates. All of the affairs and property of the condominium and of the Association shall be controlled by the officers and board of directors of the Association. A copy of the articles of incorporation which has been filed with and certified by the Secretary of State of Florida is attached hereto and marked Exhibit "B." The bylaws governing the operation of the condominium and of the Association are attached hereto and marked Exhibit "C." The Association shall have all of the rights and powers provided by the Condominium Act, the corporation statutes, the Articles of Incorporation, the Bylaws and this Declaration. Each director shall be a member, or a spouse, parent, or adult child of a member, of the Association or a person exercising the rights of an owner who is not a natural person, except that any director appointed by the Developer need not be a member of the Association.

8. VOTING RIGHTS. Each condominium unit shall be entitled to one vote at Association meetings, notwithstanding that the same owner may own more than one unit or that units may be joined together and occupied by one owner. The vote shall be cast in the manner provided in the Association bylaws.

9. COMMON EXPENSES. The common expenses shall include:

- (a) costs of operation, maintenance, repair and replacement of the common elements;
- (b) costs of management of the condominium and administrative costs of the Association including professional fees and expenses;
- (c) costs of water and sewerage service, electricity and other utilities which are not metered to the individual condominium units; this may at the discretion of the board of directors include cable television service or central antenna service;
- (d) damages to the condominium property in excess of insurance coverage;
- (e) salary of a manager or managers and their assistants and other employees, as shall be determined by the board of directors of the Association;
- (f) premium costs of fire, windstorm, flood, and other property insurance and liability insurance as provided herein; this may also include costs of directors and officers insurance if the board desires at its option to obtain same;
- (g) initial cost of installation of additions, alterations or improvements, or additional lands, leaseholds or other possessory or use rights in lands or facilities, or memberships or other interests in recreational facilities, purchased as part of the common elements for the benefit of all the members, provided that if the cost of any of such items shall be more than 10 percent of the amount of the total annual budget of the Association, the purchase or installation of such items shall first be approved by the members of the Association;
- (h) all other costs and expenses that may be duly incurred by the Association through its board of directors from time to time in operating, protecting, managing and conserving the condominium property and in carrying out its duties and responsibilities as provided by the condominium act, this declaration, the articles of incorporation, or the bylaws;

- (i) all assessments imposed by Venice Center Owners Association, Inc. to operate and maintain the Venice Center common areas pursuant to the Venice Center Declaration of Covenants, Conditions and Restrictions.
- (j) all assessments imposed by W. V. Community Association, Inc. to operate and maintain the Waterside Village Community property.
- (k) costs of maintaining landscaping along the unpaved right-of-way of roads abutting the condominium.

10. MAINTENANCE, REPAIR AND REPLACEMENT. The respective obligations of the Association and the unit owners to maintain, repair and replace the condominium property shall be as follows:

A. By The Association. The Association shall maintain, repair and replace as part of the common expense all of the common elements, including but not limited to the exterior walls, roofs, foundations and slabs of the unit buildings, except those portions of the common elements which are to be maintained, repaired and replaced by the unit owners as provided hereinafter, and except for such interior improvements to storage areas as may be made by respective unit owners. The Association shall have the irrevocable right to have access to each unit from time to time during reasonable hours as may be necessary for the maintenance, repair or replacement of any common elements therein or accessible therefrom, and during any hours for performing such emergency repairs or procedures therein as may be necessary to prevent damage to the common elements or to another unit. If the board of directors determines that any maintenance, repair, or replacement required to be made by the Association was necessitated by the carelessness, negligence, or intentional act of a unit owner, his lessees, invitees, or guests, the cost of such maintenance, repair, or replacement shall be the responsibility of the unit owner and shall be payable by such unit owner within 30 days after delivery of written notice thereof. Neither the Association nor any unit owner shall be liable for any damage to the property or person of any other unit owner or occupant caused by water intrusion into a unit through the common elements or from another unit resulting from rain leakage, pipe leakage, overflow, or bursting, or other similar source, unless the Association or unit owner is guilty of gross negligence or willful and wanton misconduct.

B. By The Unit Owners. Each unit owner shall maintain, repair and replace everything within the confines of his unit which is not part of the common elements (except as otherwise provided herein), including but not limited to:

- (a) paint, finish, covering, wallpaper and decoration of all interior walls, floors and ceiling;

- (b) all built-in shelves, cabinets, counters, storage areas, and closets;
- (c) all refrigerators, stoves, ovens, disposals, dishwashers and other kitchen equipment; all bathroom fixtures, equipment and apparatus;
- (d) all electrical, plumbing, telephone and television fixtures, apparatus, equipment, outlets, switches, wires, pipes and conduits serving only the respective unit; all electric lines between the unit and its individual service panel or meter, and all water and waste lines between the unit and the main distribution lines;
- (e) the heating and air conditioning system serving the unit including those parts of the system which are located outside of the boundaries of the unit along with any limited common element which is an appurtenance to the unit;
- (f) all windows, screening and sliding glass doors (glass in sliding glass doors must be replaced only with tempered glass);
- (g) all interior doors, walls, partitions, and room dividers; and
- (h) all furniture, furnishings and personal property contained within the respective unit.

The Association shall have a right of access to the unit as provided in the condominium act. If damage to the common elements results from the negligence of a unit owner, the cost of repairs or maintenance resulting from such negligence shall be the responsibility of the negligent unit owner and shall be payable within 30 days after delivery of written notice thereof to the unit owner. If the Association is required to take legal action to collect that amount for the cost of any repairs it shall make to the unit, the Association shall be entitled to collect the repair expenses plus interest at the maximum rate allowed by law and reasonable attorneys' fee (including appellate actions) incurred by the Association in the collection thereof.

11. INSURANCE, DESTRUCTION AND RECONSTRUCTION. Except as otherwise provided herein, the Association, as agent for and in behalf of the unit owners and their respective mortgagees, the Association shall obtain and maintain fire and extended coverage insurance with a responsible insurance company upon all of the insurable improvements of the entire condominium, including the common elements and the respective units and personal property of the Association, for the full replacement or insurable value thereof. The Association board of directors at its discretion may obtain flood insurance coverage for the common elements. The premium for all insurance shall be paid by the Association and shall be included in the assessment for common expenses. The Association board of directors shall have full authority as agents for the insureds to compromise and settle all claims against its insurance carrier and may institute legal proceedings for the collection thereof. The original policy of insurance shall be held by the Association and the institutional first mortgagees shall be furnished mortgagee endorsements

covering their respective interests. Each unit owner shall be responsible for insuring (1) his own personal property and appliances within his unit, (2) any alterations or additions to his unit made by him or by any of his predecessors in title other than Developer; and (3) all paint, finishing, covering, wallpaper, and decoration of the interior surfaces of all walls, floors, ceilings, and doors bounding, or contained within, his unit. Each unit owner shall also be responsible for insuring any improvements installed within an area assigned or designated as a limited common element that such unit owner is obligated to maintain pursuant to paragraph 10. Notwithstanding the foregoing, any insurance otherwise required to be maintained by the unit owners by the terms hereof may be included in the insurance coverage purchased by the Association and paid for as part of the common expenses, if so authorized by the Association board of directors.

In the event of a destruction or casualty loss to any of the improvements, all insurance proceeds payable under the Association's policies shall be collected by the Association. If the proceeds are in excess of an amount equal to the total annual budget, they shall be immediately paid over by the Association to a banking corporation having trust powers selected by the Association board of directors. The proceeds shall be held by the bank in trust and used for the immediate repair and reconstruction of the damaged improvements under the supervision and control of the board of directors. The insurance carrier shall not be responsible to assure that the proceeds are paid over to the trustee or are properly applied as provided herein. The bank shall disburse that proceeds held by it upon written draw requests signed by the president or vice president of the Association as reconstruction progresses. Any surplus of insurance proceeds shall be returned to the Association and added to the common surplus. In the event the proceeds are not sufficient to pay the cost of the reconstruction and the trustee's costs and reasonable fees, the Association shall supply sufficient additional funds as a part of the common expenses of the Association. The Association's insurance carrier shall not have a right of subrogation against any unit owner, but if it is determined by the board of directors that the damage was proximately caused by the gross negligence or willful and wanton misconduct or intentional acts of a unit owner, such unit owner shall be responsible to pay a sum sufficient to reimburse the Association for any deficiency in insurance proceeds, which sum shall be payable by such unit owner within 30 days after delivery or written notice thereof. In the event the insurance proceeds are less than the amount of the total budget, they need not be placed in trust but shall be held by the Association and applied directly by the board of directors for the above purposes.

In the event of a total or substantial destruction of all of the condominium improvements, the improvements shall be restored as above provided unless the owners of two-thirds of the units in this condominium and two-thirds of the units in all other condominiums, if any, operated by the Association vote to terminate this condominium. Except for the consent of institutional first mortgagees and Developer pursuant to paragraphs 16 and 17, no further consent from any other person or entity shall be necessary to effectuate a termination of the condominium in the manner above described. In the event the condominium is to be terminated, then all owners of units shall immediately convey all their right, title, and interest to their respective units to the bank trustee selected by the board of directors, to be held by such trustee in trust. The recording of each such conveyance to the trustee in the Public Records of Sarasota County will have the immediate effect of releasing all liens upon the respective unit and shall cause their instantaneous transfer to that unit owner's share of the funds to be subsequently distributed by the trustee as provided herein. Upon recording an instrument evidencing the termination of the condominium, the proportional share of each unit owner in the condominium property and, to the extent allowed by law, in all funds distributed by the trustee as herein provided shall be established in accordance with the respective values of the units prior to the destruction as such values are determined by three experienced real estate appraisers selected by the board of directors.

The trustee shall collect all insurance proceeds payable as a result of such destruction, shall collect all assets of the Association which are allocable to the units in this condominium and which may remain after the Association pays its liabilities, and shall effect a public or private sale of the condominium property, by whatever means the Association board of directors shall deem best, for the highest and best price, for cash or terms, as soon as practicable consistent with local real estate market conditions. The trustee may make partial distributions of each unit's share of the funds collected by the trustee at such times and in such aggregate amounts as the trustee and the Association board of directors may deem appropriate. In determining the amount of any partial distribution, the trustee and the Association board of directors shall ensure that sufficient funds are retained by the trustee to cover unpaid or anticipated costs, fees, or other liabilities of the Association. When the trustee has collected all insurance proceeds and all proceeds from the sale of the condominium property and, to the extent applicable, the assets of the Association and has paid all applicable Association liabilities and reasonable trustee's fees, appraiser's fees, and other costs

reasonably incurred, the trustee shall make a final distribution of each unit's share of the remaining funds held by the trustee.

Any distribution, whether partial or final, of a unit's share of the funds held by the trustee shall be made jointly to the record title owner of the unit and the record owners of any mortgages or other liens encumbering the unit at the time of the recording of the conveyance to the trustee by the unit owner. All mortgages and other liens upon the respective units shall be fully released and discharged as provided herein even though the share of a particular unit in the funds distributed by the trustee is insufficient to pay all liens in full; in such event the lienholders who had priority against the title to the unit shall have priority of payment of the unit's share of such funds.

Nothing herein provided shall in any way relieve the unit owner of his personal liability for any deficiency which may remain upon any liens which encumbered his unit at the time of his conveyance to the trustee.

Mortgagees and other lienholders shall be deemed to have evidenced their acceptance and consent to the foregoing provisions of this paragraph 11 by the acceptance of their mortgage or perfection of their liens. The provisions of this paragraph 11 may be enforced by injunction, suit for specific performance or by other appropriate remedy upon suit filed by the Association in a court of competent jurisdiction.

12. LIABILITY INSURANCE. The Association shall obtain and maintain public liability insurance covering all of the common elements and insuring the Association and the unit owners as their interests may appear in such amount as the board of directors may deem appropriate. The premiums for such insurance coverage shall be a part of the common expenses. The board of directors shall have authority to compromise and settle all claims against the Association or upon insurance policies held by the Association. The unit owners shall have no personal liability upon any such claims and nothing herein contained shall in any way be construed as imposing upon the Association a duty to assess unit owners for the purpose of raising sufficient funds to discharge any liability in excess of insurance coverage. Each unit owner will be responsible for procuring and maintaining public liability insurance covering losses which may occur in and about his particular unit, as he may deem appropriate.

13. RESTRICTIONS UPON USE. No owner, tenant or other occupant of a condominium unit shall:

- (a) use the unit for other than residence purposes (except that Developer may use a unit as a model for sales purposes);

- (b) do any of the following without prior written consent of the Association board of directors: paint or otherwise change the appearance of any exterior wall, door, window, patio or any exterior surface; place any sunscreen, blind or awning on any exterior opening; place any draperies or curtains at the windows of any unit without a solid, light color liner facing the exterior of the unit; tint, color or otherwise treat or apply anything to any window which will adversely affect the uniform exterior appearance of the building; plant any planting outside of a unit; erect any exterior lights or signs; place any signs or symbols in windows or on any exterior surface; erect or attach any structures or fixtures within the common elements; make any structural additions or alterations (except the erection or removal of non-support carrying interior partitions wholly within the unit) to any unit or to the common elements; nor fasten any objects to the walls or ceiling of a unit unless they may be removed without substantial damage to the wall or ceiling structure;
- (c) permit loud and objectionable noises or obnoxious odors to emanate from the unit or the common elements which may cause a nuisance to the occupants of other units in the sole opinion of the board;
- (d) make any use of a unit which violates any laws, ordinances or regulations of any governmental body;
- (e) fail to conform to and abide by this declaration, the articles of incorporation and bylaws of the Association, and the uniform rules and regulations in regard to the use of the units and the common elements which may be adopted from time to time by the board of directors, or fail to allow the board of directors access to the unit as permitted by the condominium act;
- (f) erect, construct or maintain any wire, antennas, garbage or refuse receptacles, or other equipment or structures on the exterior of the building or on or in any of the common elements, except with the written consent of the Association board of directors;
- (g) permit or suffer anything to be done or kept in his condominium unit or in the common elements which will increase insurance rates on any unit or on the common property;
- (h) commit or permit any public or private nuisance in the unit or in or on the common elements;
- (i) divide or subdivide a unit for purpose of sale or lease except to the owner of an adjacent unit (however a unit may be combined with an adjacent unit and occupied as one unit);
- (j) obstruct the common way of ingress or egress to the other units or the common elements;
- (k) hang any laundry, garments or other unsightly objects which are visible outside of the unit;
- (l) allow anything to remain in the common elements which would be unsightly or hazardous;
- (m) allow any rubbish, refuse, garbage or trash to accumulate in places other than the receptacles provided therefor, and or fail to keep the unit and the limited common elements appurtenant thereto in a clean and sanitary condition at all times;
- (n) allow any fire or health hazard to exist in or about the unit;
- (o) make use of the common elements in such a manner as to abridge the rights of the other unit owners to their use and enjoyment;

- (p) rent or lease a single room or less than an entire unit;
- (q) lease a unit for a period of less than three months;
- (r) allow any animals to be kept in the unit other than one dog or one cat, caged birds, and small marine animals in aquariums, all of which shall be kept in conformity with the rules and regulations of the board of directors of the Association, provided that in the event any animal becomes a nuisance to the other unit owners in the sole opinion of the board of directors, such animal shall be removed from the unit immediately; or allow any authorized pets to use the common elements except when on a leash accompanied by its owner and then only so long as the pet does not make a mess or otherwise disturb the common elements. The developer may, in its discretion grant a variance upon initial sales to purchasers owning more than one pet, to allow the pets but upon the condition that as the pets die or are transferred to others, they cannot be replaced until only a single pet remains (which then could be replaced).
- (s) park overnight any commercial truck, boats, camper, motor home, trailer, mobile home or similar vehicle in any parking area (other than in an enclosed garage), or placing a vehicle on blocks, except as may be permitted in writing by the board and except service vehicles during the time they are actually serving the unit or common elements, or use an open carport for any storage other than a vehicle or golf cart;
- (t) store a golf cart any place other than in that unit's carport or garage, or store a bicycle any place other than in the unit or that unit's storage area; or
- (u) enclose a balcony, lanai or patio without the written consent of the board of directors as to installation and design of the enclosure. Once any such enclosure is installed, maintenance thereof shall be the sole responsibility of the unit owner;
- (v) use or store a gas or charcoal grill within or about the unit or any balcony, lanai or patio; only electric grills are permitted, and they must be stored within a unit or a screened LCE area appurtenant to a unit; or
- (w) discharge saline or other regenerating solution from water softening equipment or any other chemicals into any street, easement, surface water drain or portion of the common elements so as to harmfully affect any lawn or landscaping or pollute the Venice Center drainage system.

14. SALE, TRANSFER, LEASE OR OCCUPATION OF UNIT. Prior to the sale or transfer of any unit within the condominium, the unit owner shall provide to the Association written notice reciting the name, permanent address and telephone number of the transferee party. Prior to the lease of a unit, the unit owner shall provide to the Association written notice reciting the name, permanent address and telephone number of the tenant. Further, in recognition of the compatibility and congeniality which must exist between the unit owners and occupants in order to make an undertaking such as a condominium development satisfactory and enjoyable to all parties in interest, the Board of Directors of the Association may from time to time promulgate rules and regulations requiring prior written approval of all sales, transfers, leases or occupation of a unit before such sale, transfer, lease or occupation shall be lawful, valid and effective.

The foregoing provisions shall not be applicable to conveyances from Developer.

15. ASSESSMENTS AND LIENS. The board of directors of the Association shall approve annual budgets of projected anticipated income and estimated expenses for each fiscal year, and each unit owner will be responsible for his unit's share of such annual assessment based upon its proportionate share of the common expenses as provided herein. Assessments shall be due and payable in advance to the Association on the first day of the first, fourth, seventh and tenth months of each fiscal year, as discussed in Paragraph XI of the Bylaws. In addition, the board of directors shall have the power to levy special assessments against the unit owners in proportion to each unit's share of the common expenses, if necessary to cover unanticipated expenditures which may be incurred during the fiscal year. Any assessments or other indebtedness owing by unit owners to the Association which are not paid when due shall bear interest from the due date until paid at the rate of 18% per annum or such other rate as may be permitted by law and established by resolution of the board. The Association shall have the remedies and liens provided by the condominium act with respect to unpaid assessments, which shall include accrued interest and reasonable attorneys' fees incurred by the Association incident to the collection of such assessment or other indebtedness or enforcement of such lien, including attorneys' fees for appellate proceedings. If an assessment (regular or special) is payable in installments and a unit owner defaults in the payment of an installment, the remaining installments of the assessment may be accelerated to maturity. Accelerated assessments shall be due and payable on the date the claim of lien is filed. The board of directors may require each unit owner to maintain a minimum balance on deposit with the Association in an amount which shall not exceed one-fourth of the current annual assessment, to provide for working capital and to cover contingent expenses of the Association from time to time.

16. RIGHTS OF INSTITUTIONAL FIRST MORTGAGEES. All savings and loan associations, banks, and insurance companies, or their subsidiaries or affiliates, along with FNMA or FHLMC, holding first mortgages upon any of the condominium units are herein referred to as "institutional first mortgagees." The termination of the condominium and any amendments to the provisions of this Declaration materially affecting the rights of institutional first mortgagees shall require the written consent of institutional first mortgagees holding at least 51 percent of such first mortgages, except for amendments adding phases pursuant to paragraph 19 and amendments by Developer pursuant to paragraph 22 which do not require such consent. Such consent shall not be unreasonably withheld.

17. RIGHTS OF DEVELOPER. Rights of Developer with regard to the election of directors of the Association are set forth in the articles and bylaws of the Association. Developer may terminate such right by relinquishing control of the election of the board of directors to the unit owners at any time. As long as Developer holds units in this condominium for sale in the ordinary course of business, this declaration and the Association Articles and Bylaws shall not be amended in a manner which may be adverse to Developer's sales program, nor the condominium terminated, without the written consent of Developer.

At the time of recording this Declaration, construction of all of the condominium units and improvements has not been completed. Developer reserves all necessary rights and easements with respect to the condominium property, to complete such construction and to effect the sale or lease of all of the condominium units. As long as Developer holds units or lots in any project within the Venice Center planned development for sale in the ordinary course of business, Developer shall have the right to exhibit such signs and sales paraphernalia as may be desirable to effect such sales and may use one or more of the units or lots and the common elements for offices, models, and other uses appropriate for the promotion of sales and for the development and management of property in Waterside Village. Developer reserves the right to use the name "South Preserve I at Waterside Village" or any similar name in connection with future developments within Venice Center or other projects.

18. EASEMENTS. The respective rights and obligations of the unit owners, the Association, Developer, and others concerning easements affecting the condominium property shall include the following:

(a) **Reserved and Granted by Developer.** Developer hereby reserves for the benefit of itself, its successors and assigns perpetual, nonexclusive easements in gross for ingress and egress and for the installation, construction, repair, maintenance, and replacement of lines, pipes, wells, drains, conduits, catch basins, cables, equipment, apparatus, structures, roads, driveways, and other improvements for private or public utility services of all kinds, including without limitation, water, sewer, drainage, irrigation, fire protection, electricity, telephone, cable television, and trash disposal, over, under, through, and across the easements shown upon the condominium plat and that part of the common elements which is not occupied by buildings or other improvements. The easements herein reserved and granted may serve this condominium or other portions of the Venice Center.

(b) **Granted to Unit Owners.** Each unit owner and his guests and invitees are hereby granted a nonexclusive perpetual easement for ingress and egress to and from his respective unit through the common elements. Each unit owner shall have a perpetual easement for encroachments which may exist now or in the future by inaccuracies in construction or settlement or movement of the building, which encroachments shall be allowed to

remain undisturbed until they no longer exist. Further, unit owners within any section of Waterside Village are granted easements across private roads, access easements and travelways located within this condominium for purposes of gaining access to private roadways within Venice Center granting access to public roads.

(c) **Granted to Utilities.** There is hereby granted to all public and private utility companies rendering utility services to the condominium as of the time of recording of this declaration a perpetual nonexclusive easement for the construction, installation, maintenance, repair, and replacement of the equipment, structures, and other improvements by which such utility services are respectively provided over, under, across, and through such unimproved portion of the common elements as may be reasonably necessary therefor. The use of any easement granted hereunder shall not include the right to disturb any building or structure on the common elements, and any damage caused to same shall be repaired at the expense of the company causing such damage. In the event a utility company's use of an easement granted hereunder causes a disturbance of the surface of the land, the roadways, grass, landscaping, and other improvements which are disturbed shall be restored promptly by the utility company as nearly as possible to their prior condition.

(d) **Authority of Association.** The Association shall have the right and authority to grant easements under, over, across, and through the condominium property to such persons or entities and for such purposes as the Association board of directors may deem appropriate by recording in the public records of Sarasota County, an instrument duly executed by the president or vice-president of the Association.

19. PHASED DEVELOPMENT. Developer intends to develop this condominium in three phases pursuant to the provisions of Section 718.403, Florida Statutes 2002. There are 12 units in Phase 1. There are 8 units proposed for Phase 2, and 12 units proposed for Phase 3. Developer reserves the right to modify the number of units in Phases 2 and 3 but in no event will the number of units in Phase 2 be less than 7 or more than 8, or the number of units in Phase 3 be less than 10 units minimum or 12 units maximum. If no modifications are made to the number of units presently proposed for each phase, when all phases are submitted to condominium ownership, the condominium will contain a total of 32 units. If modifications are made, upon submission of all phases to condominium ownership the condominium may contain a minimum of 29 units and a maximum of 32 units.

The land which may become part of the condominium and upon which each phase is to be built and the number and general size of the units included in each phase are shown on the condominium plat. Prior to submission of any subsequent phase to condominium ownership, Developer may make nonmaterial changes in the legal description of the phase, which changes will be set forth in the amendment adding the phase to condominium. Phase 1 constitutes the initial phase of the condominium and is hereby submitted to condominium ownership. Phases 2 and 3

each will become part of the condominium only when and if such phase is submitted to condominium ownership by the recording of an amendment to this Declaration in the public records of Sarasota County. Such amendments shall not require the execution, joinder, or consent of individual unit owners or holders of recorded liens thereon (including institutional first mortgagees) or the Association. Such amendments shall take effect at the time of recording.

When a phase is added to the condominium, the common elements of such phase shall merge with the common elements of prior phases and will become part of one condominium, and the share of the common expenses, common elements, and common surplus of each unit will be adjusted as provided in Paragraph 4. In addition, when a phase is added, each added unit will have one vote in the affairs of the Association, which will result in the diluting of the voting rights of the prior existing units. If a phase is not developed and added as a part of the condominium by a date not later than seven years after date of recordation of this declaration of condominium, the lands in such phase will not become part of the condominium and the units (if any) shown in such phase will not become part of the condominium and will not share in the common elements, common surplus, or common expenses of the condominium nor will they acquire any voting rights in the Association (unless the property within such phase is subsequently developed as a separate condominium that the Association agrees to operate, in which case each unit in such separate condominium would acquire one vote in the affairs of the Association). Time-share estates will not be created with respect to the units in any phase.

The approximate location and general size of the buildings, improvements, and units proposed to be constructed in each phase is set forth on the condominium plat. Developer also reserves the right to modify the design, elevation, size, configuration, location, and directional bearing of the buildings, improvements, and units in each phase from that shown on the condominium plat.

The actual size and configuration of any unit depends upon the floor plan selected for the unit. The unit floor plans presently available are depicted on the condominium plat. The configuration, location, and size of each building and unit whose construction has been substantially completed as of the recording of this Declaration, and the floor plan for each such unit, is shown on the condominium plat recorded herewith. Although a specific floor plan may be designated on the plat for each uncompleted unit, Developer reserves the right to construct any such unit according to any floor plan now or hereafter made available. In no event, however, will any unit in the

condominium be less than 500 square feet, or more than 5,000 square feet, in size. As construction of a building is completed, the configuration, location, and size of the building and the units contained therein, and their respective floor plans, shall be designated by an appropriate amendment to the condominium plat.

Developer's intent in reserving the right to construct uncompleted buildings and units according to modified plans is to accommodate to a reasonable extent the building and unit type preferences of purchasers of units that are uncompleted at the time of purchase. Developer's right to establish the floor plans for units in any building and to otherwise modify the design, elevation, size, configuration, location, and directional bearing of such building and the units contained therein shall terminate upon the recording of a surveyor's certificate certifying to the substantial completion of the building and establishing the building's "as-built" location and dimensions.

20. VENICE CENTER. Pursuant to the terms of the Venice Center Declaration of Covenants, Conditions and Restrictions ("Master Covenants") recorded in Official Records Book 2238, Page 2733 of the Public Records of Sarasota County, Florida, as amended from time to time, each unit owner in South Preserve I at Waterside Village shall have the nonexclusive right to use the Venice Center common areas. In consideration thereof, all owners of property within Venice Center shall pay the pro rata share of all costs and expenses of operating, maintaining, repairing and replacing such facilities and the insurance and taxes thereon and the utilities and salaries connected therewith. The common areas are managed and operated by Venice Center Owners Association, Inc., a Florida nonprofit corporation (herein called "Master Association"), of which each unit owner in the entire Waterside Village complex, including South Preserve I at Waterside Village, shall automatically be a member. The Master Association has the power to assess each unit of South Preserve I at Waterside Village a sum equal to its pro rata share of such expenses and to file a lien against the unit to secure the payment thereof. Such assessment shall be collected by the Association as part of the common expenses of South Preserve I at Waterside Village.

South Preserve I at Waterside Village is part of the area of Venice Center known as "Waterside Village." The lands of Waterside Village are subject to the Declaration of Management Covenants for Waterside Village at Venice Center, and the Articles of Incorporation and Bylaws for W. V. Community Association, Inc. (collectively the "Community Documents"). Waterside Village consists of the lands identified in the Community Documents, as amended, from time to time.

There have been constructed certain common recreational facilities (the "Waterside Village Recreational Facilities") within Waterside Village. These facilities will be for the exclusive use and enjoyment of property owners in Waterside Village. The facilities presently include a clubhouse, plus two swimming pools with deck, and bathhouse, but the facilities may be expanded to include other structures and uses.

The Waterside Village Recreational Facilities will be made available for use by Waterside Village unit and lot owners. Ownership of the facilities, and the land upon which they will be constructed, ultimately will be transferred to W. V. Community Association, Inc. ("Community Association"), whose primary purpose is to operate and maintain the facilities and whose members are all associations operating condominiums or subdivisions in Waterside Village. The facilities, and the land upon which they will be constructed, will not be a part of the common elements of any condominium in Waterside Village and will not be subject to any lease. Once the Waterside Village Recreational Facilities are made available for use by Waterside Village unit owners, all expenses for the operation, maintenance, repair, replacement, and improvement of the facilities will be shared by the Association with such other associations as may be operating condominiums or subdivisions in Waterside Village in the manner set forth in the Community Documents. Responsibility for the actual operation and maintenance of the facilities shall be vested in the Community Association. The Community Association shall be authorized to construct, install and maintain certain other community property, including private roads, street lighting systems and sidewalks, all as further discussed in the Community Documents.

There may be lakes or retention areas included within the common elements, or Master Association or Community Association property. The water level in such lakes will rise and fall as a function of rainfall and water table levels. There is no assurance or guarantee that all lakes will be full at any given time.

21. REMEDIES FOR DEFAULT. In addition to the remedies provided by statute and common law and the remedies elsewhere provided herein, a default by a unit owner, tenant or occupant of a unit in complying with the provisions of the condominium act, this declaration, articles of incorporation, bylaws and the regulations and rules promulgated by the Association board of directors, shall entitle the other unit owners or the Association to injunctive relief or money damages or both. In any such legal or equitable action or proceeding the prevailing party shall be

entitled to recover his costs and expenses, including reasonable attorneys' fees to be determined by the court for trial and appellate proceedings.

22. AMENDMENTS. This Declaration may be amended by the Developer as set forth in the last paragraph of this Paragraph 22, or by affirmative vote of the owners of two-thirds of the units, except that provisions relating to percentage of ownership and sharing of common expenses, voting rights of the unit owners, configuration or size of a unit, materially altering or modifying appurtenances to a unit and termination of the condominium may be amended only with the written consent of all persons adversely affected thereby. The rights granted to institutional first mortgagees, the rights and easements reserved by Developer, and the rights and easements granted to private and public utilities under the terms of this Declaration or the condominium plat may not be amended or terminated without the written consent of the parties involved. The articles of incorporation and bylaws may be amended by a simple majority vote of all voting rights of all members of the Association and to that extent this Declaration may be amended without two-thirds vote.

Except for amendments by Developer as provided herein, no amendment shall be effective unless it be in writing, executed by the president or vice president and attested by the secretary of the Association with the formalities required for a conveyance of real property in the State of Florida, and recorded in the public records of Sarasota County. Any amendment so executed and recorded shall be prima facie evidence that the amendment was duly adopted in accordance with the requirements of this declaration, the articles of incorporation and the bylaws. It shall not be necessary for the individual unit owners or holders of recorded liens thereon (except institutional first mortgage holders as herein provided) to join in or consent the execution of any amendment. Until such time as Developer shall have conveyed title to all of the units in the condominium, no amendments to the declaration, articles of incorporation, or bylaws which might adversely affect the sale of units shall be effective without its written consent.

Developer shall have the right and irrevocable power to amend this Declaration and the exhibits recorded herewith as may be necessary or desirable from time to time prior to the conveyance of all units by Developer to (a) identify, locate and dimension any units which are not completed at the date of this Declaration and to provide surveyor certificates of completion, (b) correct any errors or omissions in the declaration or any exhibits hereto; (c) make the documents comply with the requirements of any statutory provisions or any state or federal rules or regulations

or county ordinances; or (d) gain acceptance or approval of any institutional mortgage lender or title insurer. Such amendments shall be executed by Developer, and the joinder or further consent of individual unit owners or holders of recorded liens or other interests therein, including institutional first mortgagees, shall not be required. All amendments shall take effect immediately upon recordation in the public records of Sarasota County.

23. TERMINATION. The condominium property may be removed from the provisions of this Declaration and the condominium terminated at any time by a vote of eighty percent of the voting rights of all unit owners, or a vote of two-thirds of unit owners in the event of total or substantial destruction as set forth in paragraph 11, and in either case provided such termination shall have the written consent of the institutional first mortgagees as provided in paragraph 16, and consent of the Developer if Developer owns unsold units within the condominium. The termination shall be effected by an instrument in writing signed by the president or vice-president and secretary of the Association with the formalities of a deed and duly recorded in the public records of Sarasota County. In the event of termination, the rights of owners of mortgages or other liens and the procedure for liquidation of the condominium assets as provided herein with respect to total or substantial destruction shall apply and shall be under the supervision and control of the banking trustee selected by the board of directors of the Association.

24. NO TIME SHARING. Neither individual condominium units nor the entire condominium shall create time-share estates or interval ownership estates, nor shall any unit owner or the Association allow such use.

25. BINDING EFFECT. All provisions of the declaration shall be enforceable as equitable servitudes and shall run with the land and shall be in full force and effect until a particular provision is duly amended or until the declaration is duly terminated. Any gender used herein shall include all genders and legal entities, and the plural number shall include the singular and the singular shall include the plural.

26. SEVERABILITY. If any provisions of this declaration, the condominium plat, the articles of incorporation, or the bylaws or any section, sentence, clause, phrase or word thereof, or the application thereof in any circumstance, is held invalid by a court of competent jurisdiction, the validity of the remainder of such instruments and of the application thereof in other circumstances shall not be affected thereby.

INSTRUMENT # 2004193126
40 PGS

IN WITNESS WHEREOF, Developer has caused this Declaration to be signed by its duly authorized officers the 14th day of Sept., 2004.

Witnesses:

WATERSIDE PRESERVE, INC.,
a Florida corporation

[Signature]
(Signature of Witness)
James A. Connelly
(Print Name of Witness)

By: [Signature]
Stephen E. Lattmann
As its: President

[Signature]
(Signature of Witness)
Debbie L. Connelly
(Print Name of Witness)

STATE OF FLORIDA
COUNTY OF SARASOTA

SWORN TO AND SUBSCRIBED BEFORE ME this 14th day of Sept. 2004, by Stephen E. Lattmann as President of Waterside Preserve, Inc., a Florida corporation, on behalf of the corporation. He is personally known to me or has produced _____ as identification and did not take an oath. If no type of identification is indicated, the above-named person is personally known to me.

[Signature]
Signature of Notary Public

Print Name of Notary Public

(Notary Seal)

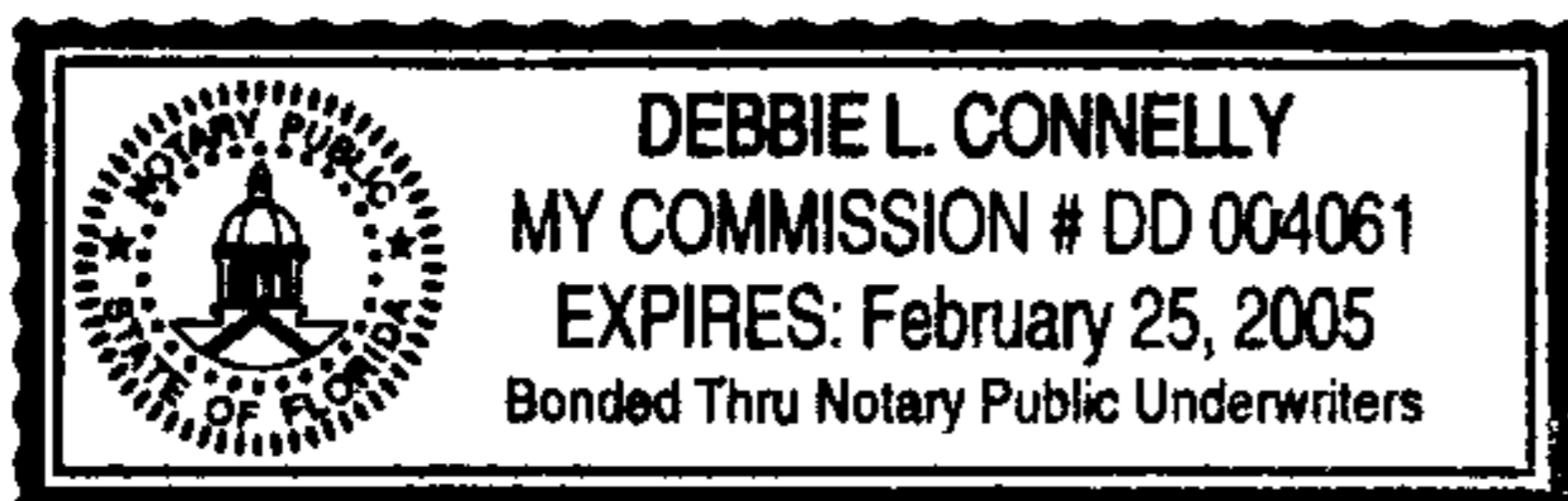

I am a Notary Public of the State of Florida,
and my commission expires on _____.

JOINDER OF ASSOCIATION INSTRUMENT # 2004193126
40 PGS

SOUTH PRESERVE I AT WATERSIDE VILLAGE ASSOCIATION, INC., a Florida nonprofit corporation, hereby joins in and consents to the foregoing declaration of condominium and hereby agrees to the provisions thereof and assumes the obligations imposed upon it therein.

IN WITNESS WHEREOF, the corporation has caused this joinder to be executed in its name by its duly authorized officers and caused its corporate seal to be hereunto affixed this 14th day of Sept., 2004.

Witnesses:

[Signature]
(Signature of Witness)
James A. Connelly
(Print Name of Witness)

[Signature]
(Signature of Witness)
Debbie L. Connelly
(Print Name of Witness)

SOUTH PRESERVE I AT WATERSIDE VILLAGE ASSOCIATION, INC.

By: [Signature]
Stephen E. Lattmann
As its: President

(CORPORATE SEAL)

STATE OF FLORIDA
COUNTY OF SARASOTA

The foregoing instrument was acknowledged before me this 14th day of Sept., 2004, by Stephen E. Lattmann as President of SOUTH PRESERVE I AT WATERSIDE VILLAGE ASSOCIATION, INC., a Florida nonprofit corporation, on behalf of the corporation. He is personally known to me or has produced _____ as identification and did not take an oath. If no type of identification is indicated, the above-named person is personally known to me.

(Notary Seal)

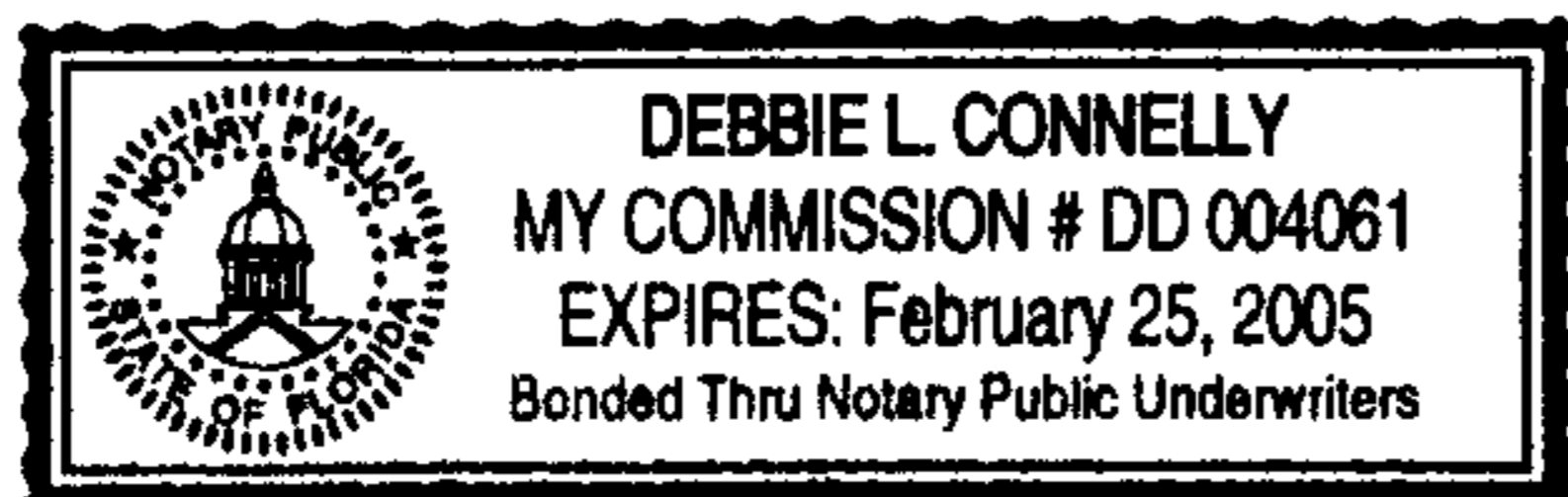

[Signature]
Signature of Notary Public

Print Name of Notary Public

I am a Notary Public of the State of Florida, and my commission expires on _____.

INSTRUMENT # 2004193126
40 PGS

SOUTH PRESERVE I AT WATERSIDE VILLAGE, A CONDOMINIUM
LYING IN A PORTION OF SECTION 15, TOWNSHIP 39 SOUTH, RANGE 19 EAST
FLORIDA
SARASOTA COUNTY

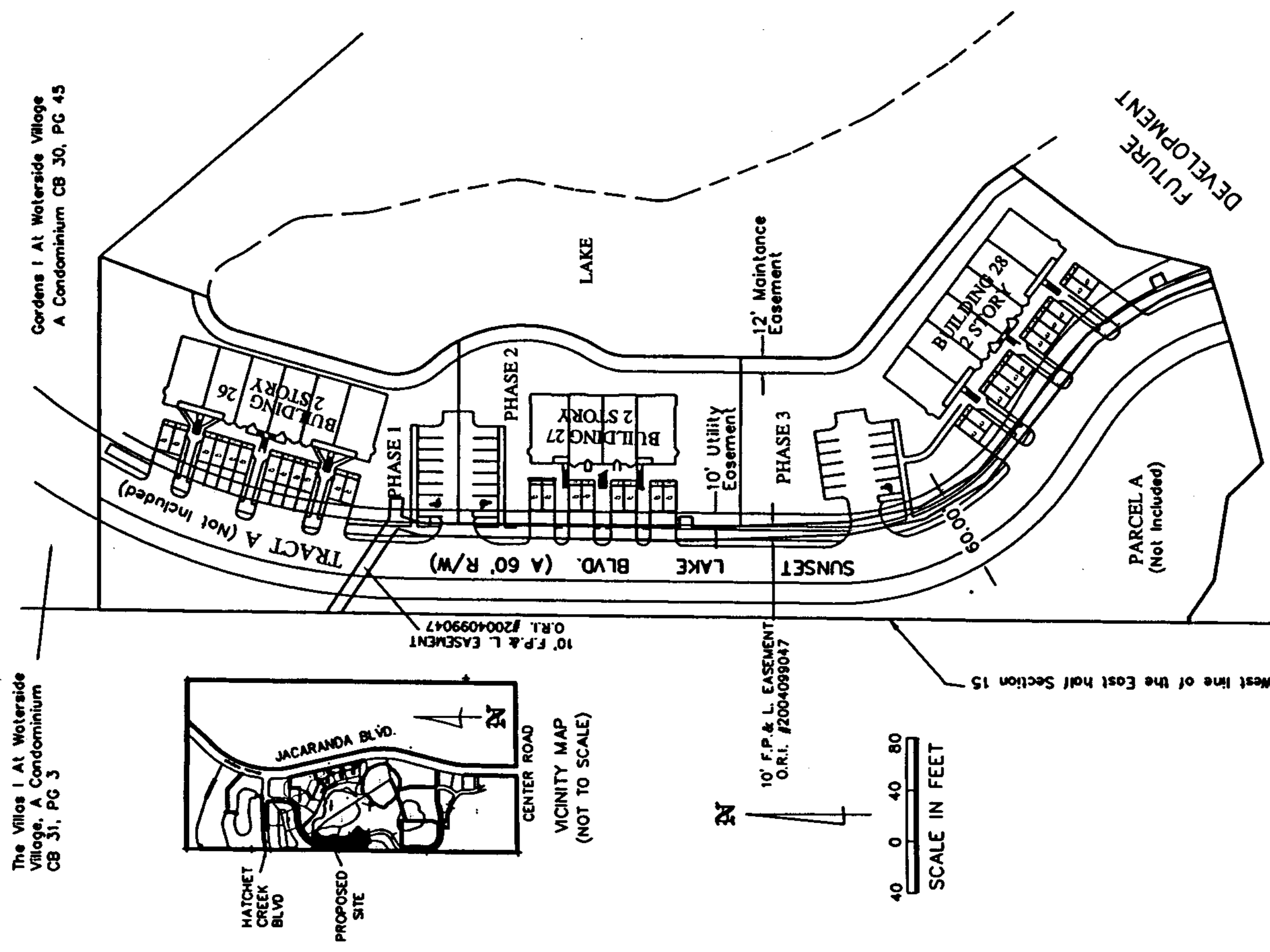

- SURVEYOR'S NOTES:**
- (1) This plot is subject to change due to design changes or construction requirements in the field. Amendments to the plot will be recorded in the public records to show all improvements as completed. Phase 1 is substantially complete at this time. Phases 2 & 3 are not complete at this time.
 - (2) Improvements within the common elements, such as but not limited to, water meters, water lines, storm drains, sanitary sewers, sidewalks and trees, have not been located.
 - (3) Limited Common Elements (LCE) are defined in the Declaration of Condominium and include:
 - (A) Carports, Utility rooms.
 - (B) C 101 through C 206 denotes carports, which are hereby assigned as Limited Common Elements to the respective units within that phase to which they numerically correspond. E.g. C 101 in Phase 1 is a Limited Common Element appurtenant to Unit 101, Building 26.
 - (4) Elevations refer to N.V.G.D. datum 1929, Sarasota County benchmark R-437.
 - (5) Bearings shown hereon are based on the West line of the East 1/4 of Section 15, Township 39 South, Range 19 East, being N.00°33'46"E.
 - (6) Property lies in Flood Zone X, elevation required "NA". F.I.R.M. PANEL #334, DATED 9/3/92.
 - (7) TYPICAL
 - (A) Private Road width 24 feet.
 - (B) Parking Space 9'x20'
 - (C) Carports 10'x20'
 - (D) Utility Room 4'x10'.
 - (8) Areas not designated a "Unit or LCE" are common elements, subject to the terms of the Declaration of Condominium.
 - (9) Tract A is not included within the condominium. Tract A is a private road that will serve these buildings as well as properties other than this condominium.
 - (10) Parcel A is not included within the condominium.
 - (11) Easements designated "lake maintenance easements" run in favor of the Venice Center Property Owners Association, Inc. and the W.V. Community Association, Inc.

CERTIFICATE OF SURVEYOR

I, the undersigned registered Land Surveyor, hereby certify that:

1. This plot, designated as Exhibit "A" to the Declaration of Condominium for SOUTH PRESERVE I AT WATERSIDE VILLAGE, A CONDOMINIUM, consisting of seven sheets, is a correct representation of a survey of the land described and shown hereon.
2. All existing easements encumbering the land are shown on this plot.
3. The construction of Building No. 26, Units 101-106, 201-206, Phase 1, and the common element facilities serving said building are substantially completed as of 10-1-04.
4. The construction of the buildings lying in phases 2 & 3, and the common element facilities serving said buildings are not substantially completed as of 10-1-04.
5. The plot, together with the provision of the Declaration describing the condominium property, is an accurate representation of the location and dimensions of said improvements.
6. As to the units located within said buildings, the identification, locations and dimensions of the common elements, and of each unit can be determined from the plat and the provisions of said declaration.
7. All planned improvements including, but not limited to, landscaping, utility services and access to said units, and common element facilities serving the building(s) in which said units are located have not been completed.

STRAYER SURVEYING & MAPPING, INC.
Licensed Surveyor, Sarasota, FL, No. 6659

Robert E. Strayer 10/6/04
Robert E. Strayer, P.E.
Florida Surveyor's Certificate No. 5027

LEGEND
CB = CONDOMINIUM PLAT BOOK
PG = PAGE
R/W = RIGHT OF WAY

Strayer Surveying & Mapping, Inc.
292 Sherman Boulevard
West Palm Beach, Florida 33411
Tel: (561) 844-8800
Fax: (561) 844-3477
e-mail address: strayer@strayermapping.com

SOUTH PRESERVE I AT WATERSIDE VILLAGE, A CONDOMINIUM
 LYING IN A PORTION OF SECTION 15, TOWNSHIP 39 SOUTH, RANGE 19 EAST
 SARASOTA COUNTY
 FLORIDA

INSTRUMENT # 2004193126
40 PGS

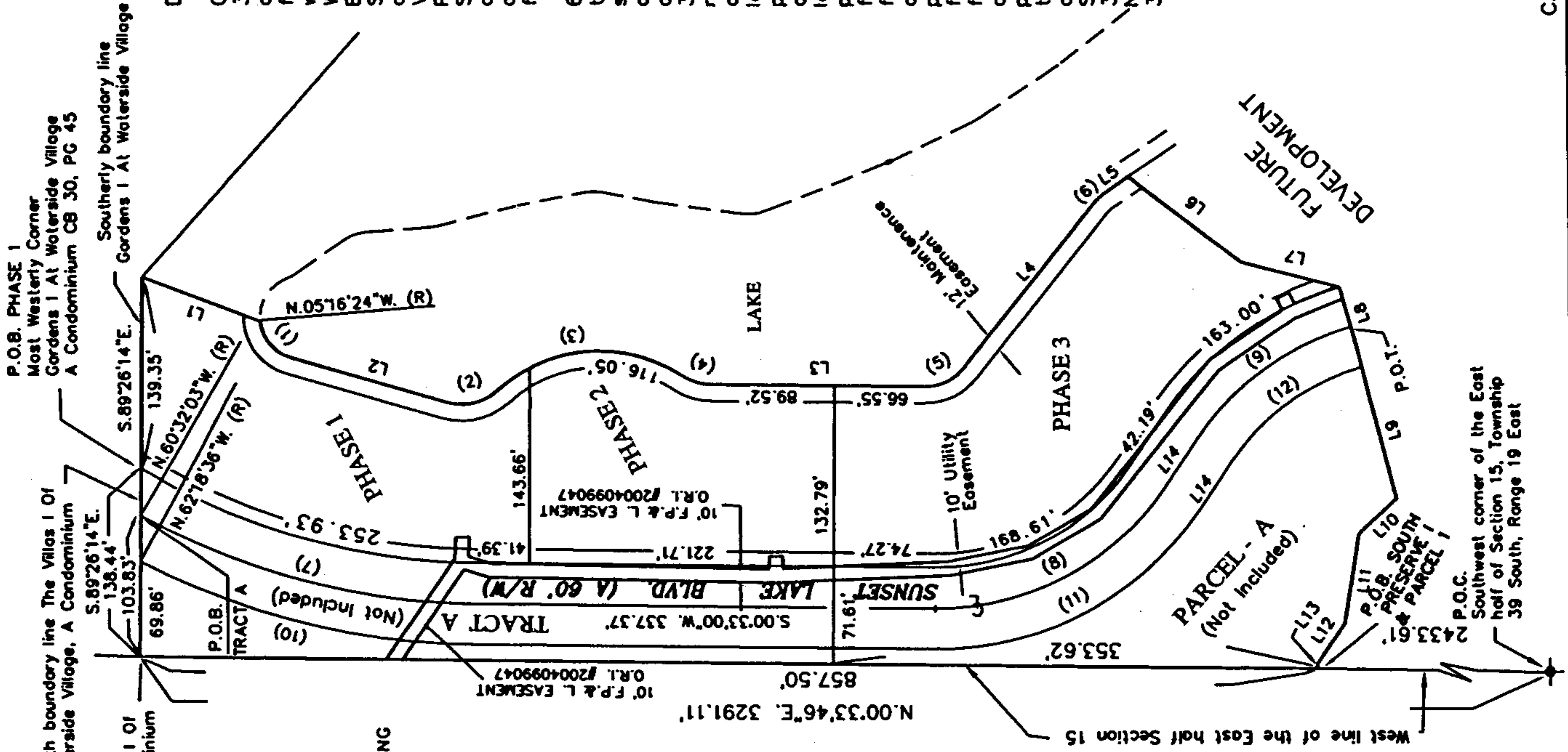

Description for South Preserve I at Waterside Village, A Condominium
 Commence at the southwest corner of the east half of Section 15, Township 39, Range 19 East, Sarasota County, Florida. Thence N.00°33'46"E., along the west line of the east half of Section 15, a distance of 2433.61 feet to a Point Of Beginning.; thence continue N.00°33'46"E., along said west line, a distance of 857.50 feet to the Southwest corner of The Villas At Waterside Village, A Condominium; as per plat recorded in Condominium Book 31; Page 3, Public Records of Sarasota County, Florida; thence S.89°26'14"E., along the south boundary line of said condominium plat a distance of 138.44 feet to the most westerly corner of Gardens I Of Waterside Village, A Condominium as per plat recorded in Condominium Plat Book 30, Page 45, Public Records of Sarasota County, Florida.; thence continue S.89°26'14"E., along the South boundary line of said Condominium Plat, a distance of 139.35 feet; thence leaving said south line S.20°41'50"W., a distance of 90.29 feet to a point on the arc of a curve, lying N.05°16'24"W., from the radius point; thence traverse along the arc of said curve, to the left, in a Southwesterly direction having: a radius of 30.00 feet, a central angle of 68°50'32", a chord bearing of S.50°18'19"W., and a chord length of 33.92 feet; thence along the arc of said curve, 36.05 feet to the point of tangency of said curve; thence S.15°53'03"W., a distance of 119.41 feet to the point of curvature of a curve to the left, having: a radius of 40.00 feet, a central angle of 58°13'45", a chord bearing of S.13°13'49"E., and a chord length of 38.92 feet; thence along the arc of said curve, 40.65 feet to the point of reverse curvature of a curve to the right, having: a radius of 110.00 feet, a central angle of 75°28'51", a chord bearing of S.04°36'16"E., and a chord length of 134.66 feet; thence along the arc of said curve, 144.91 feet to the point of reverse curvature of a curve to the left, having: a radius of 40.00 feet, a central angle of 32°35'10", a chord bearing of S.16°50'35"W., and a chord length of 22.44 feet; thence along the arc of said curve, 22.75 feet to the point of tangency of said curve; thence S.00°33'00"W., a distance of 156.07 feet, a central angle of 51°43'32", a chord bearing of S.25°18'47"E., and a chord length of 30.54 feet; thence along the arc of said curve, 31.60 feet to the point of tangency of a curve to the left, having: a radius of 35.00 feet, a central angle of 51°43'32", a chord bearing of S.25°18'47"E., and a chord length of 30.54 feet; thence along the arc of said curve, 31.60 feet to the point of tangency of a curve to the right, having: a radius of 35.00 feet, a central angle of 17°03'28", a chord bearing of S.42°38'49"E., and a chord length of 10.38 feet; thence along the arc of said curve, 10.42 feet to the point of tangency of said curve; thence S.34°07'05"E., a distance of 20.77 feet; thence S.37°03'34"W., a distance of 102.57 feet; thence S.14°29'43"W., a distance of 73.23 feet; thence S.74°15'43"W., a distance of 60.00 feet; thence S.75°23'01"W., a distance of 99.45 feet; thence N.42°52'35"W., a distance of 38.55 feet; thence N.80°28'30"W., a distance of 66.92 feet; thence N.55°41'27"W., a distance of 35.39 feet; thence N.89°27'00"W., a distance of 3.72 feet to the Point Of Beginning. LESS Tract A and Parcel A.

LEGEND
 CB = CONDOMINIUM BOOK
 PG = PAGE
 P.O.B. = POINT OF BEGINNING
 P.O.C. = POINT OF COMMENCEMENT
 P.O.T. = POINT OF TERMINUS
 R/W = RIGHT-OF-WAY

SCALE IN FEET
 0 40 80

South boundary line The Villas I Of Waterside Village, A Condominium
 S.89°26'14"E.
 138.44'
 103.83'
 69.86'
 P.O.B. TRACT A
 P.O.B. PHASE 1
 Most Westerly Corner Gardens I At Waterside Village A Condominium CB 30, PG 45
 S.89°26'14"E.
 139.35'
 N.60°32'03"W. (R)
 N.62°18'36"W. (R)
 S.89°26'14"E.
 139.35'
 N.05°16'24"W. (R)
 SOUTHERLY BOUNDARY LINE GARDENS I AT WATERSIDE VILLAGE

CURVE TABLE

NO.	RADIUS	DELTA	ARC	CHORD	CHORD BEARING
1	30.00'	68°50'32"	36.05'	33.92'	S.50°18'19"W.
2	40.00'	58°13'45"	40.65'	38.92'	S.13°13'49"E.
3	110.00'	75°28'51"	144.91'	134.66'	S.04°36'16"E.
4	40.00'	32°35'10"	22.75'	22.44'	N.16°50'35"E.
5	35.00'	51°43'32"	31.60'	30.54'	S.25°18'47"E.
6	35.00'	17°03'28"	10.42'	10.38'	S.42°38'49"E.
7	500.00'	28°54'57"	252.34'	249.67'	S.15°00'28"W.
8	200.00'	56°53'39"	198.60'	190.54'	S.27°53'50"E.
9	200.00'	40°36'22"	141.74'	138.79'	S.36°02'28"E.
10	530.00'	27°08'25"	251.05'	248.71'	S.14°07'12"W.
11	230.00'	56°53'39"	228.39'	219.12'	S.27°53'50"E.
12	170.00'	40°36'22"	120.82'	117.98'	S.36°02'28"E.

LINE TABLE

Line	Bearing	Distance
L1	S.20°41'50"W.	90.29'
L2	S.15°53'03"W.	119.41'
L3	S.00°33'00"W.	156.07'
L4	S.51°10'33"E.	154.47'
L5	S.34°07'05"E.	20.77'
L6	S.37°03'34"W.	102.57'
L7	S.14°29'43"W.	73.23'
L8	S.74°15'43"W.	60.00'
L9	S.75°23'01"W.	99.45'
L10	N.42°52'35"W.	38.55'
L11	N.80°28'30"W.	66.92'
L12	N.55°41'27"W.	35.39'
L13	N.89°27'00"W.	3.72'
L14	S.56°20'39"E.	42.19'
L15	S.89°26'14"E.	103.83'

Shroyer Surveying & Mapping, Inc.
 783 Shennock Boulevard
 Venice, Florida 33593
 (941) 496-9488
 Fax (941) 497-8188
 e-mail address - stroyer@shroyer.com



SOUTH PRESERVE I AT WATERSIDE VILLAGE, A CONDOMINIUM
 LYING IN A PORTION OF SECTION 15, TOWNSHIP 39 SOUTH, RANGE 19 EAST
 SARASOTA COUNTY
 FLORIDA

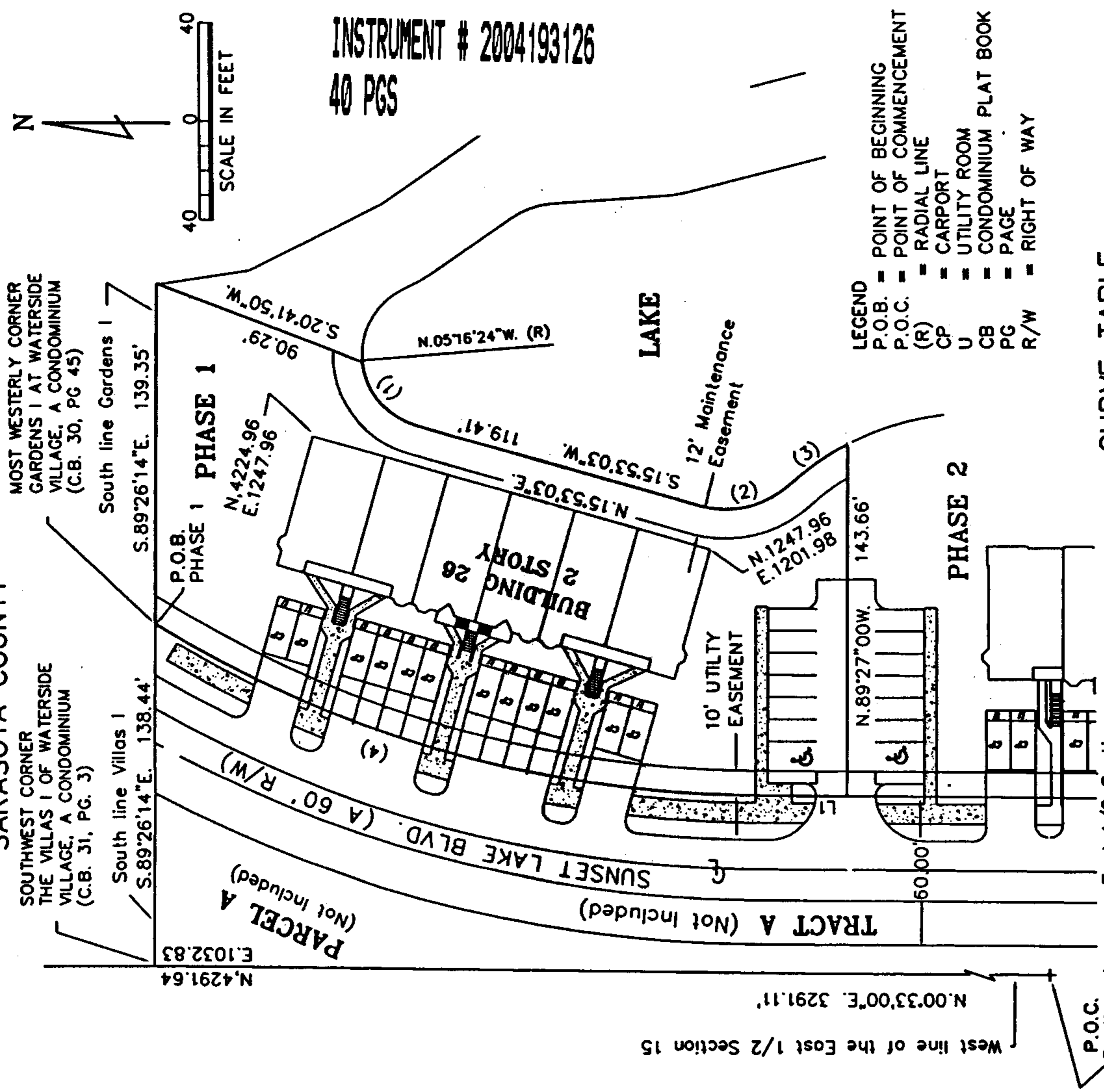

Description for Phase 1:
 Commence at the southwest corner of the east half of Section 15, Township 39 South, Range 19 East, Sarasota County, Florida. Thence N.00°33'46"E., along the west line of the east half of Section 15, a distance of 3291.11 feet to the Southwest corner of The Villas I Of Waterside Village, A Condominium; as per plat recorded in Condominium Book 31; Page 3, Public Records of Sarasota County, Florida; thence S.89°26'14"E., along the south boundary line of said condominium plat a distance of 138.44 feet for a Point Of Beginning, at the most westerly corner of Gardens I At Waterside Village, A Condominium as per plat recorded in Condominium Plat Book 30, Page 45, Public Records of Sarasota County, Florida; thence continue S.89°26'14"E., along the South boundary line of said Condominium Plat, a distance of 139.35 feet; thence leaving said south line S.20°41'50"W., a distance of 90.29 feet to a point on the arc of a curve, lying N.05°16'24"W., from the radius point; thence traverse along the arc of said curve, to the left, in a Southwesterly direction having: a radius of 30.00 feet, a central angle of 68°50'32", a chord bearing of S.50°18'19"W. and a chord length of 33.92 feet; thence along the arc of said curve, 36.05 feet to the point of tangency of said curve; thence S.15°53'03"W., a distance of 119.41 feet to the point of curvature of a curve to the left, having: a radius of 40.00 feet, a central angle of 58°13'45", a chord bearing of S.13°13'49"E. and a chord length of 38.92 feet; thence along the arc of said curve, 40.65 feet to the point of reverse curvature of a curve to the right, having: a radius of 110.00 feet, a central angle of 15°02'07", a chord bearing of S.34°49'38"E. and a chord length of 28.78 feet; thence along the arc of said curve, 28.87 feet to the end of said curve; thence N.89°27'00"W., a distance of 143.66 feet; thence N.00°33'00"E., a distance of 41.39 feet to the point of curvature of a curve to the right, having: a radius of 470.00 feet, a central angle of 30°57'18", a chord bearing of N.16°01'39"E. and a chord length of 250.85 feet; thence along the arc of said curve, an arc length of 253.93 feet to the Point Of Beginning.

Parcel contains 0.86 Acre more or less

Description for Parcel A:
 Commence at the southwest corner of the east half of Section 15, Township 39 South, Range 19 East, Sarasota County, Florida; thence N.00°33'46"E., along the west line of said east half of Section 15, a distance of 2433.61 feet for a Point Of Beginning. Thence continue N.00°33'46"E., along said west line, a distance of 857.50 feet to the southwest corner of The Villas I At Waterside Village, A Condominium as per plat recorded in Condominium Book 31, Page 3, Public Records of Sarasota County, Florida; thence leaving said west line, S.89°26'14"E., along the south boundary line of said Condominium Plat, a distance of 69.86 feet to a point on the arc of a curve, having a radius 530 feet, and lying N.62°18'36"W., from the radius point; thence traverse along the arc of said curve to the left, in southwesterly direction, having: a central angle of 27°08'25", a chord bearing of S.14°07'12"W. and a chord length of 248.71 feet; thence along the arc of said curve, 251.05 feet to the point of tangency of said curve; thence S.00°33'00"W., a distance of 337.37 feet to the point of curvature of a curve to the left, having: a radius of 230.00 feet, a central angle of 56°53'39", a chord bearing of S.27°53'50"E. and a chord length of 219.12 feet; thence along the arc of said curve, 228.39 feet to the point of tangency of said curve; thence S.56°20'39"E., a distance of 42.19 feet to the point of curvature of a curve to the right, having: a radius of 170.00 feet, a central angle of 40°36'22", a chord bearing of S.36°02'28"E. and a chord length of 117.98 feet; thence along the arc of said curve, an arc length of 120.82 feet to the end of said curve; thence S.75°23'01"W., a distance of 99.45 feet; thence N.42°52'35"W., a distance of 38.55 feet; thence N.80°28'30"W., a distance of 66.92 feet; thence N.55°41'27"W., a distance of 35.39 feet; thence N.89°27'00"W., a distance of 3.72 feet to the Point Of Beginning.

Parcel contains 0.95 acres, more or less.

INSTRUMENT # 2004193126
 40 PGS

- LEGEND**
- P.O.B. = POINT OF BEGINNING
 - P.O.C. = POINT OF COMMENCEMENT
 - (R) = RADIAL LINE
 - CP = CARPORT
 - U = UTILITY ROOM
 - CB = CONDOMINIUM PLAT BOOK
 - PG = PAGE
 - R/W = RIGHT OF WAY

CURVE TABLE

NO.	RADIUS	DELTA	ARC	CHORD	CHORD BEARING
1	30.00'	68°50'32"	36.05'	33.92'	N.50°18'19"E.
2	40.00'	58°13'45"	40.65'	38.92'	N.13°13'49"W.
3	110.00'	15°02'07"	28.87'	28.78'	S.34°49'38"E.
4	470.00'	30°57'18"	253.93'	250.85'	N.16°01'39"E.

LINE TABLE

Line	Bearing	Distance
L1	N.00°33'00"E.	41.39'

Stroyer Surveying & Mapping, Inc.
 763 Shermock Boulevard
 Venice, Florida 34283
 (941) 496-9466
 Fax (941) 497-6166
 e-mail address - stroyersurveying@comcast.net

335 Terminal Road
 Fort Charlotte, Florida 33853
 (813) 624-4900
 Fax (813) 624-3471



LYING IN A PORTION OF SECTION 15, TOWNSHIP 39 SOUTH, RANGE 19 EAST FLORIDA SARASOTA COUNTY

INSTRUMENT # 2004193126
40 PGS

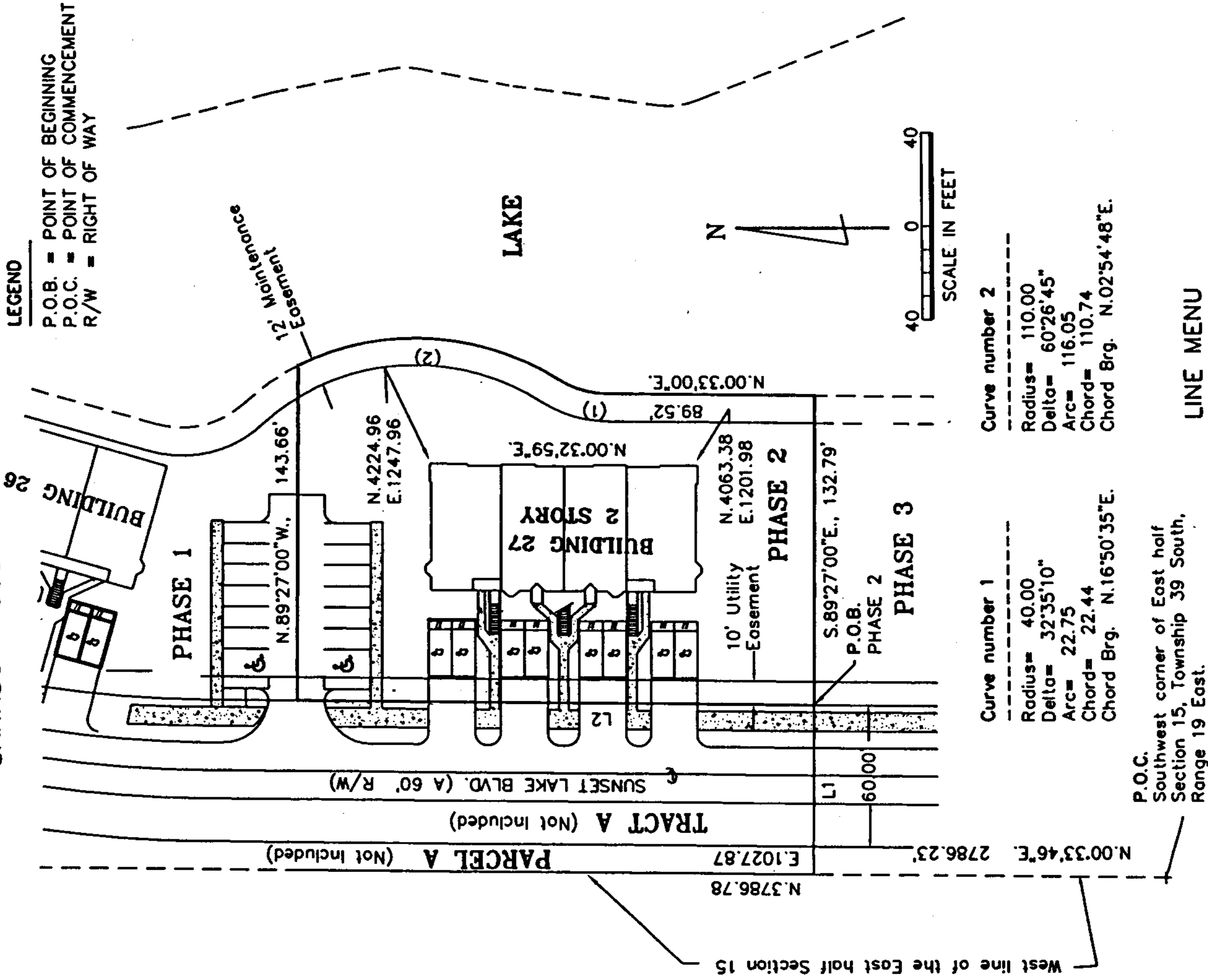

Description for Phase 2:

Commence at the southwest corner of the east half of Section 15, Township 39, South, Range 19 East, Sarasota County, Florida. Thence N.00'33'46"E., along the west line of said Section 15, a distance of 2786.23 feet, thence leaving said west line, S.89'27'00"E., a distance of 71.61 feet; for a Point Of Beginning. Thence continue S.89'27'00"E., a distance of 132.79 feet; N.00'33'00"E., a distance of 89.52 feet to the point of curvature of a curve to the right, having: a radius of 40.00 feet, a central angle of 32'35'10", a chord bearing of N.16'50'35"E. and a chord length of 22.44 feet; thence along the arc of said curve, 22.75 feet to the point of reverse curvature of a curve to the left, having: a radius of 110.00 feet, a central angle of 60'26'45", a chord bearing of N.02'54'48"E. and a chord length of 110.74 feet; thence along the arc of said curve, 116.05 feet to the end of said curve; thence N.89'27'00"W., a distance of 143.66 feet; thence S.00'33'00"W., a distance of 221.71 feet to the Point Of Beginning.

Parcel contains 0.72 acre, more or less.

Description for Tract A:

Commence at the southwest corner of the east half of Section 15, Township 39 South, Range 19 East, Sarasota County, Florida; thence N.00'33'46"E., along the west line of said east half of Section 15, a distance of 3291.11 feet to the southwest corner of The Villas I Of Waterside Village, A Condominium, as per plat recorded in Condominium Book 31, page 3, Public Records of Sarasota County, Florida; thence leaving said west line, N.89'26'14"E., along the south boundary line of said Condominium Plat, a distance of 103.83 feet to a point on the arc of a curve, having a radius 500 feet and lying N.60'18'35"W., from the radius point, said point being the Point Of Beginning, of a 60 foot road right-of-way, lying 30 feet each side of and parallel to the following described centerline. Thence traverse along the arc of said curve to the left, in a southerly direction, having: a central angle of 28'54'57", a chord bearing of S.15'00'29"W. and a chord length of 249.67 feet; thence along the arc of said curve, 252.34 feet to the point of tangency of said curve; thence S.00'33'00"W., a distance of 337.37 feet to the point of curvature of a curve to the left, having: a radius of 200.00 feet, a central angle of 56'53'39", a chord bearing of S.27'53'50"E. and a chord length of 190.54 feet; thence along the arc of said curve, 198.60 feet to the point of tangency of said curve; thence S.56'20'39"E., a distance of 42.19 feet to the point of curvature of a curve to the right, having: a radius of 200.00 feet, a central angle of 40'36'22", a chord bearing of S.36'02'28"E. and a chord length of 138.79 feet; thence along the arc of said curve, 141.74 feet, to the Point Of Terminus. The side lines of said tract to be shortened or prolonged to meet the angle points and boundary lines.

Parcel contains 1.33 Acres more or less.

SCALE IN FEET

Curve number	Radius	Delta	Arc	Chord	Chord Brg.
Curve number 1	40.00	32'35'10"	22.75	22.44	N.16'50'35"E.
Curve number 2	110.00	60'26'45"	116.05	110.74	N.02'54'48"E.

LINE MENU

Line	Bearing	Distance
L1	S.89'27'00"E.	71.61'
L2	S.00'33'00"W.	221.71'

Shroyer Surveying & Mapping, Inc.
263 Shroyer Building
Venice, Florida 33593
(941) 496-8488
Fax (941) 497-6186
e-mail address - ssm@shroyer.com

SOUTH PRESERVE I AT WATERSIDE VILLAGE, A CONDOMINIUM

LYING IN A PORTION OF SECTION 15
TOWNSHIP 39 SOUTH, RANGE 19 EAST
SARASOTA COUNTY
FLORIDA

INSTRUMENT # 2004193126
40 PGS

- LEGEND
- P.O.B. = POINT OF BEGINNING
 - P.O.C. = POINT OF COMMENCEMENT
 - R/W = RIGHT OF WAY
 - U = UTILITY ROOM
 - CP = CARPORT
 - (R) = RADIAL

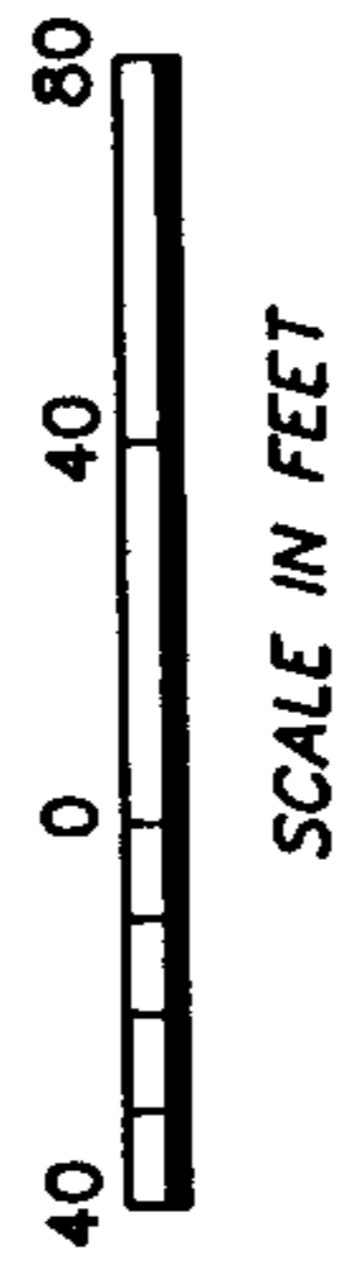
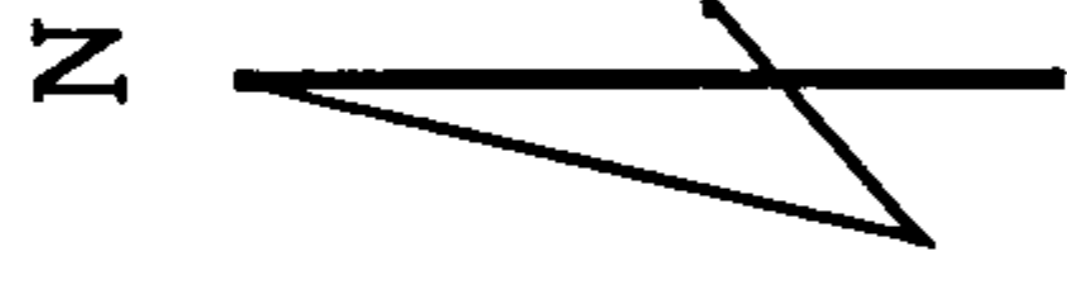

LINE TABLE

Line	Bearing	Distance
L1	S.34°07'05"E.	20.77'
L2	N.56°20'39"W.	42.19'
L3	N.00°33'00"E.	74.27'

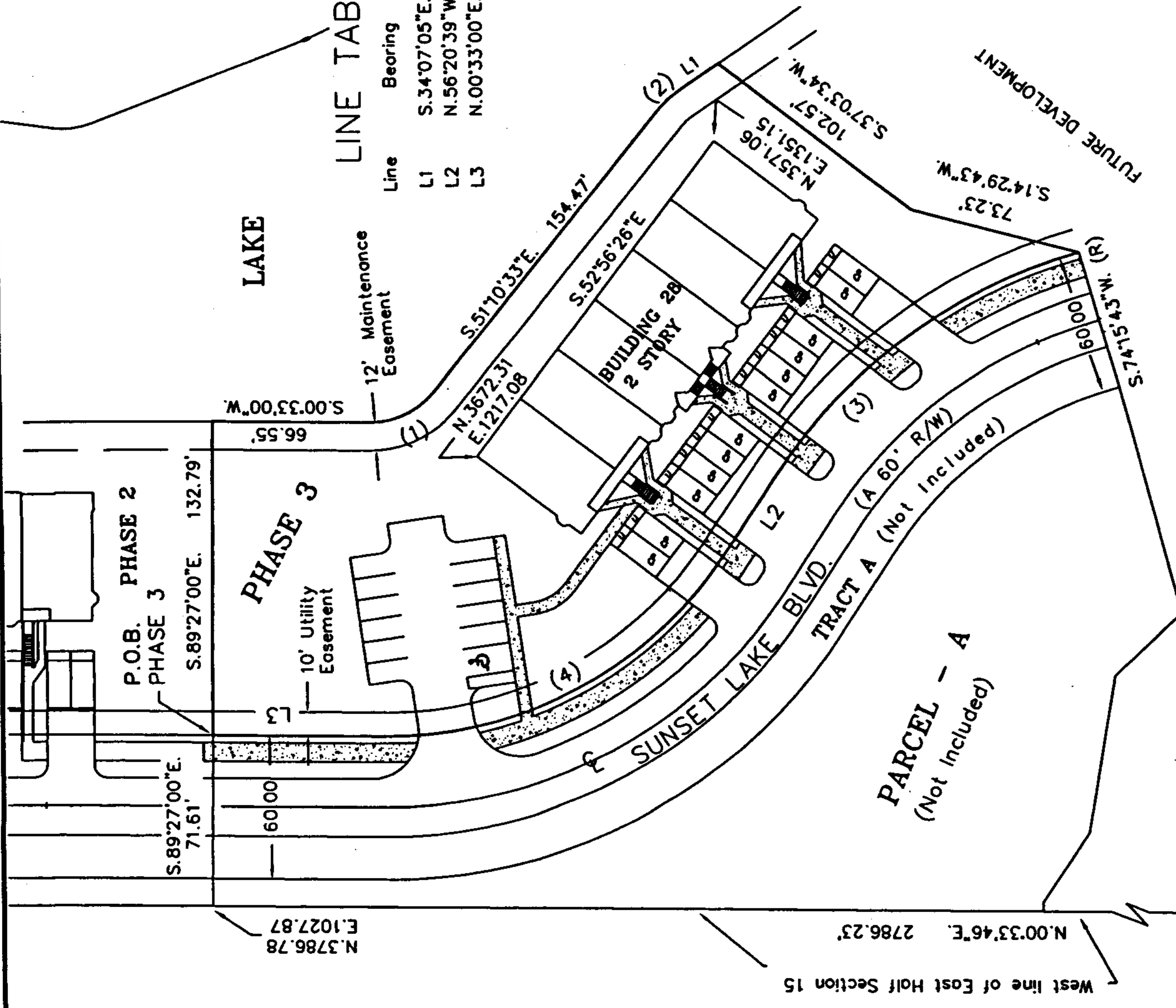

CURVE TABLE

NO.	RADIUS	DELTA	ARC	CHORD	CHORD BEARING
1	35.00'	51°43'32"	31.60'	30.54'	N.25°18'47"W.
2	35.00'	17°03'28"	10.42'	10.38'	S.42°38'49"E.
3	230.00'	40°36'22"	163.00'	159.61'	N.36°02'28"W.
4	170.00'	56°53'39"	168.81'	161.96'	N.27°53'50"W.

Description for Phase 3:

Commence at the southwest corner of the east half of Section 5, Township 39 South, Range 19 East, Sarasota County, Florida. Thence N.00°33'46"E., along the west line of the east half of said Section 15, a distance of 2786.23 feet; thence leaving said west line, S.89°27'00"E., a distance of 71.61 for a Point Of Beginning. Thence continue S.89°27'00"E., a distance of 132.79 feet; thence S.00°33'00"W., a distance of 66.55 feet to the point of curvature of a curve to the left, having: a radius of 35.00 feet, a central angle of 51°43'32", a chord bearing of S.25°18'47"E. and a chord length of 30.54 feet; thence along the arc of said curve, 31.60 feet to the point of tangency of said curve; thence bearing of S.42°38'49"E. and a chord length of 10.38 feet; thence along the arc of said curve, 10.42 feet to the point of tangency of said curve; thence bearing of S.42°38'49"E. and a chord length of 10.38 feet; thence along the arc of said curve, 10.42 feet to the point of tangency of said curve; thence S.34°07'05"E., a distance of 20.77 feet; thence S.37°03'34"W., a distance of 102.57 feet; thence S.14°29'43"W., a distance of 73.23 feet; to a point on a curve, lying N.74°15'43"E., from the radius point; thence traverse along the arc of said curve to the left, in a northerly direction, having: a radius of 230.00 feet, a central angle of 40°36'22", a chord bearing of N.36°02'28"W., and a chord length of 159.61 feet; thence along the arc of said curve, a distance of 163.00 feet; to the point of tangency of said curve; thence N.56°20'39"W., a distance of 42.19 feet to the point of curvature of a curve to the right, having: a radius of 170.00 feet, a central angle of 56°53'39"W., a chord bearing of N.27°53'50"W., a chord length of 161.96 feet; thence along the arc of said curve 168.81 feet, to the point of tangency; thence N.00°33'00"E., a distance of 74.27 feet to the Point Of Beginning.

Parcel contains 1.11 Acres, more or less.

Shayer Surveying & Mapping, Inc.

783 Sharnock Boulevard
Venice, Florida 34293
(941) 498-9488
Fax (941) 497-6186
e-mail address - slroyersurveying@comcast.net

SOUTH PRESERVE I AT WATERSIDE VILLAGE, A CONDOMINIUM

LYING IN A PORTION OF SECTION 15, TOWNSHIP 39 SOUTH, RANGE 19 EAST
FLORIDA
SARASOTA COUNTY

INSTRUMENT # 2004193126
40 PGS

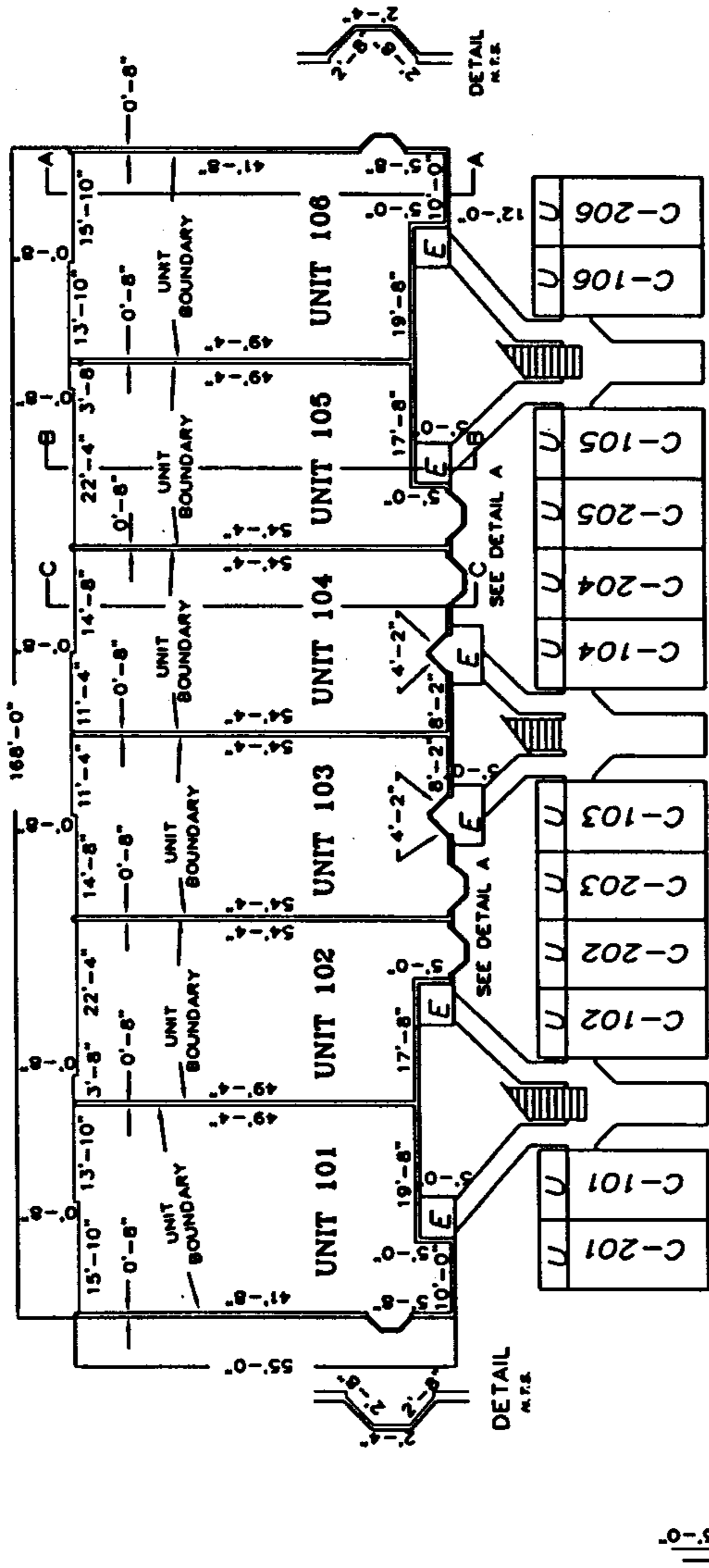

FIRST FLOOR PLAN
BUILDINGS 26 & 28
Scale 1" = 20'

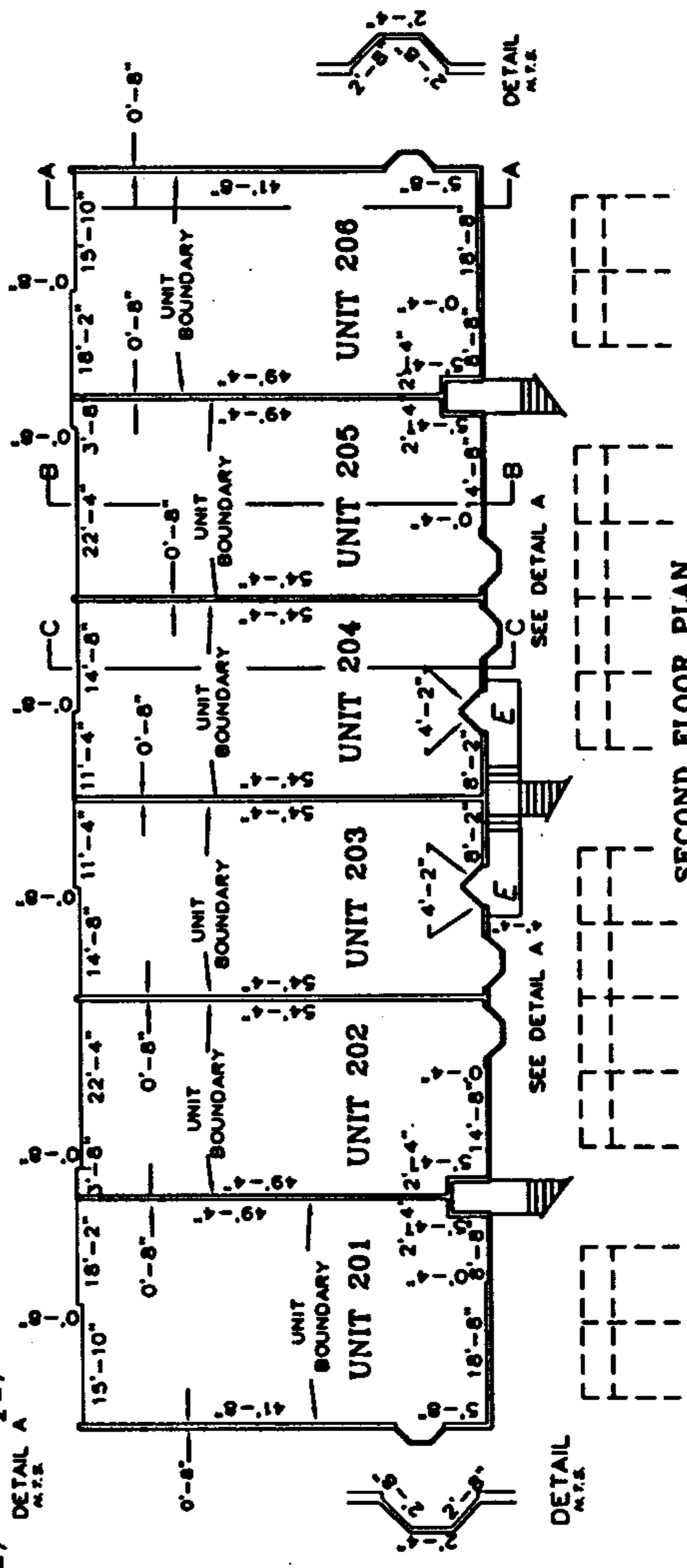

SECOND FLOOR PLAN
BUILDINGS 26 & 28
Scale 1" = 20'

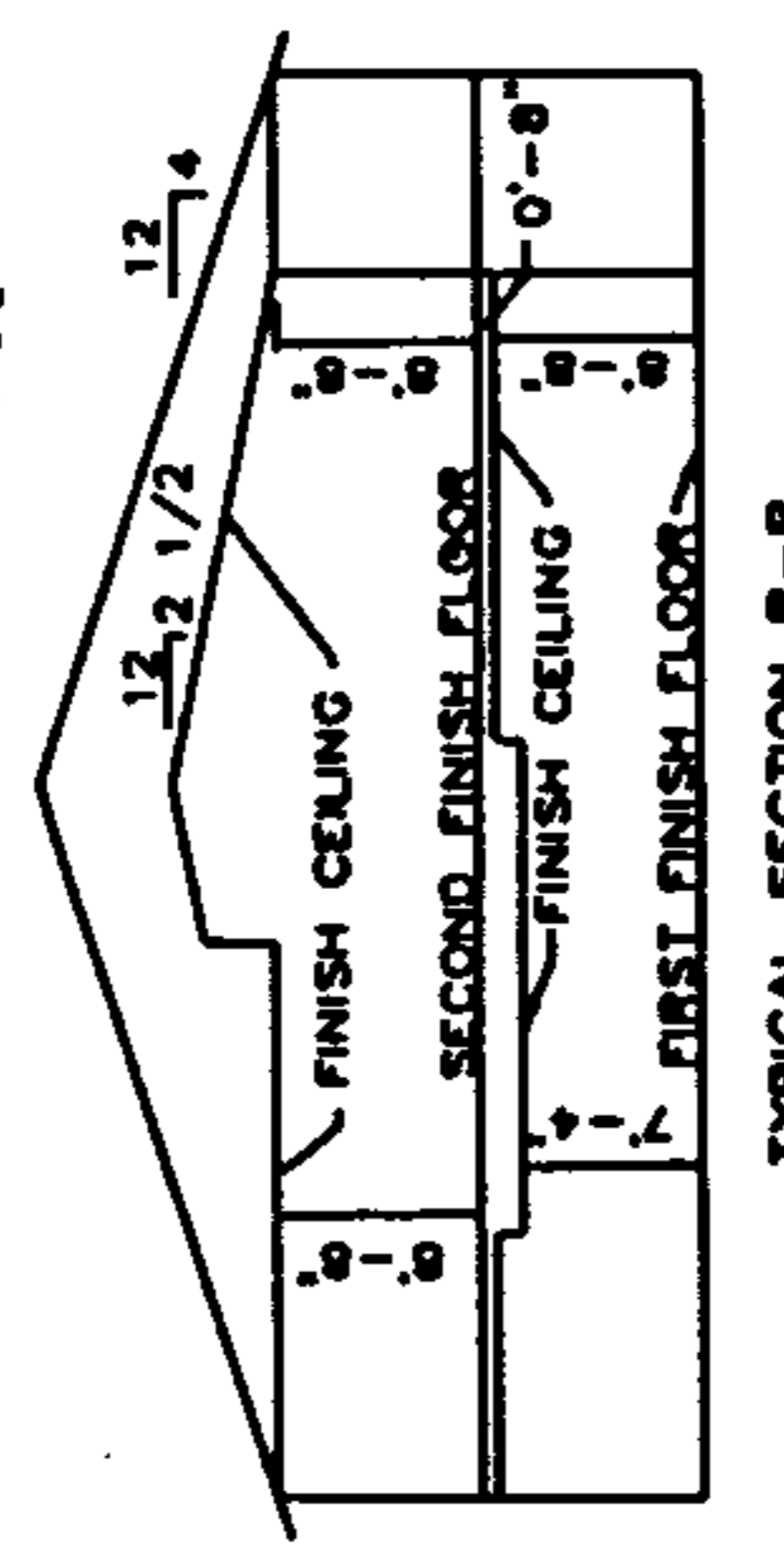

TYPICAL SECTION B-B

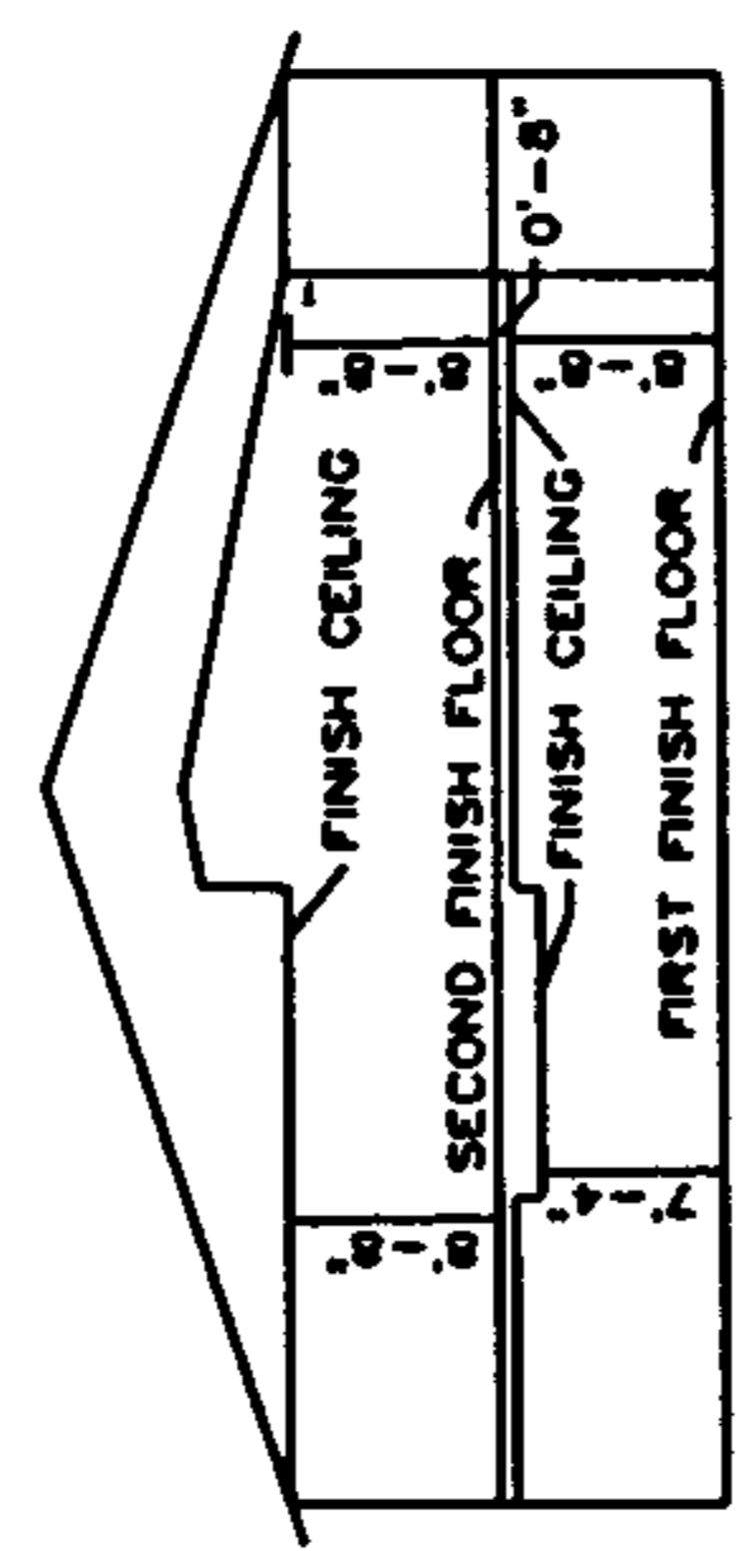

TYPICAL SECTION C-C

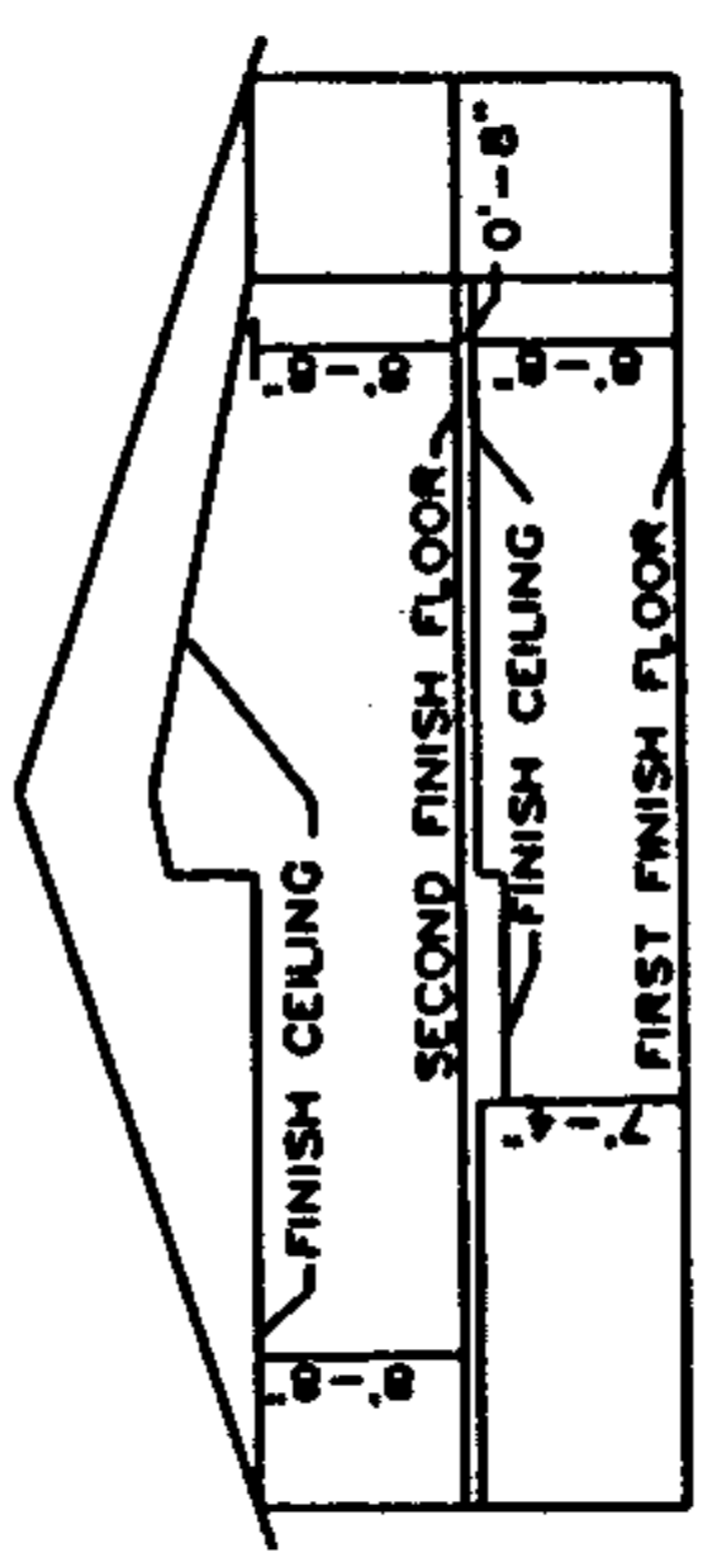

TYPICAL SECTION A-A

TYPICAL ELEVATIONS BUILDINGS 26 & 28
(NOT TO SCALE)

- LEGEND
C = CARPORT
U = UTILITY ROOM
B = BALCONY

NOTE: All unit dimensions refer to inside dimensions of the unit and are subject to slight variances which may occur during construction.



Shayer Surveying
& Mapping, Inc.
783 SHUMOCK AVENUE
VENICE, FLORIDA 34913
(941) 486-5448, FAX (941) 497-8188
E-MAIL ADDRESS: shayer@shayermapping.com

SOUTH PRESERVE I AT WATERSIDE VILLAGE, A CONDOMINIUM

LYING IN A PORTION OF SECTION 15, TOWNSHIP 39 SOUTH, RANGE 19 EAST
SARASOTA COUNTY
FLORIDA

INSTRUMENT # 2004193126
40 PGS

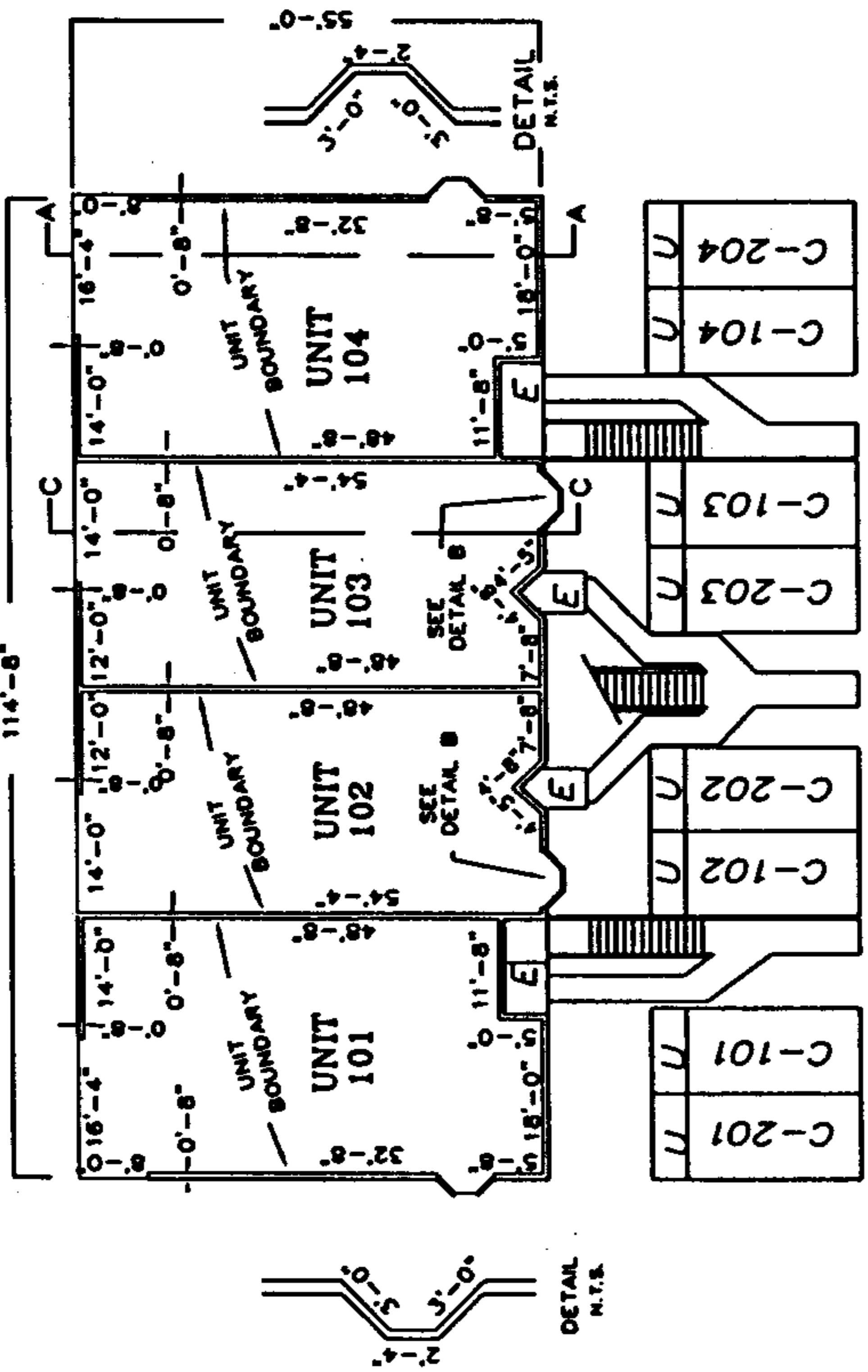

FIRST FLOOR PLAN
BUILDING 27
Scale 1" = 20'

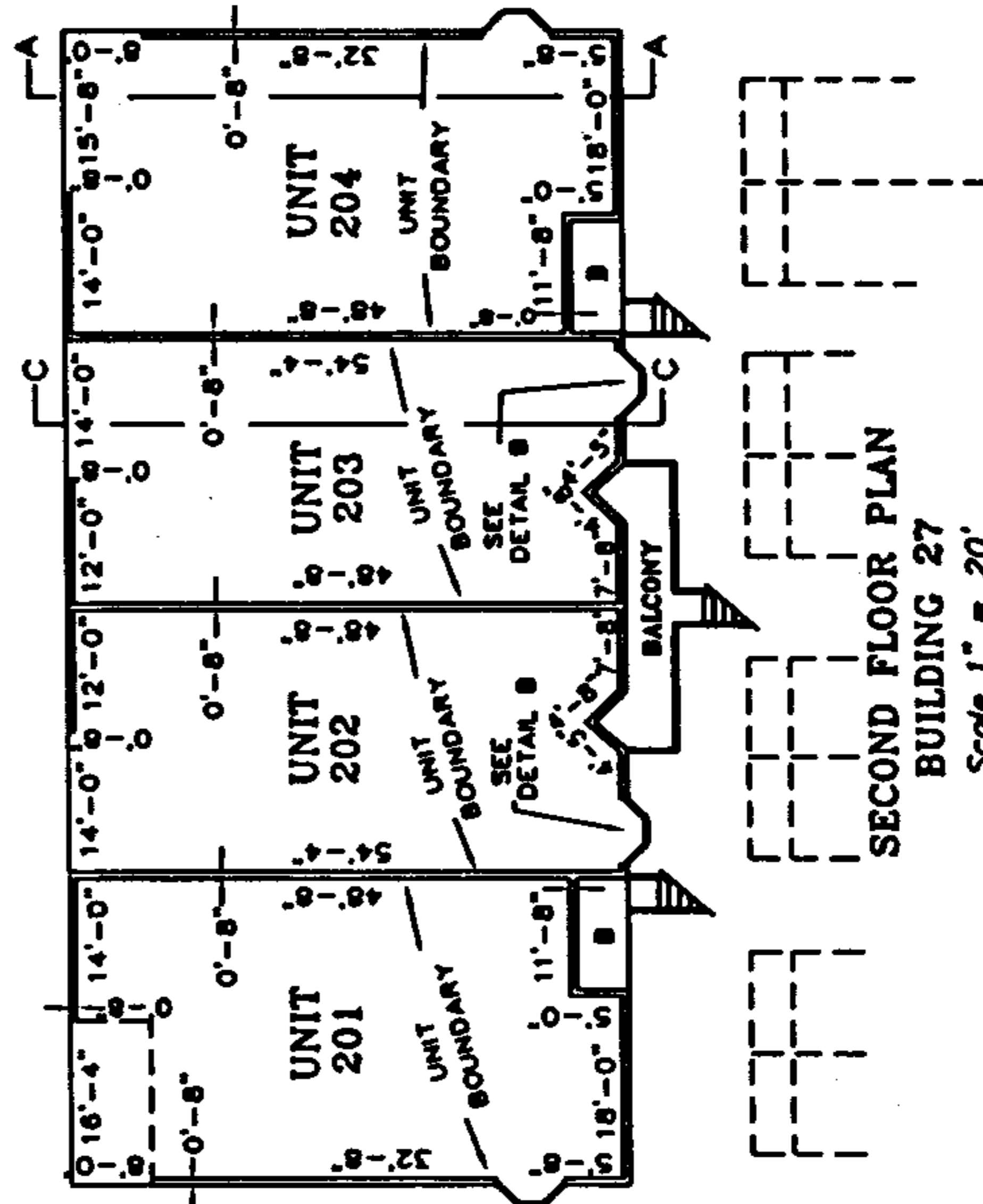

SECOND FLOOR PLAN
BUILDING 27
Scale 1" = 20'

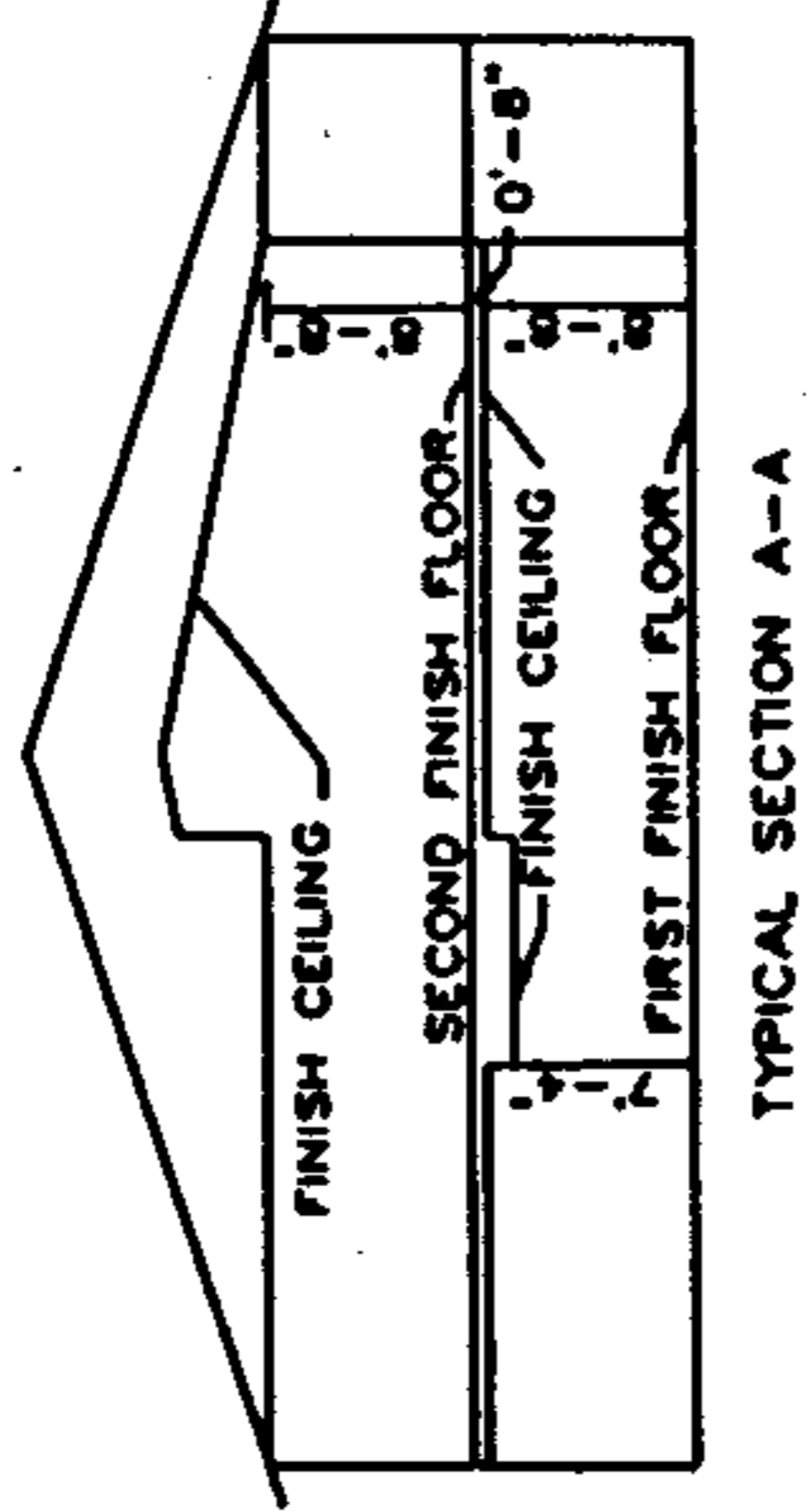
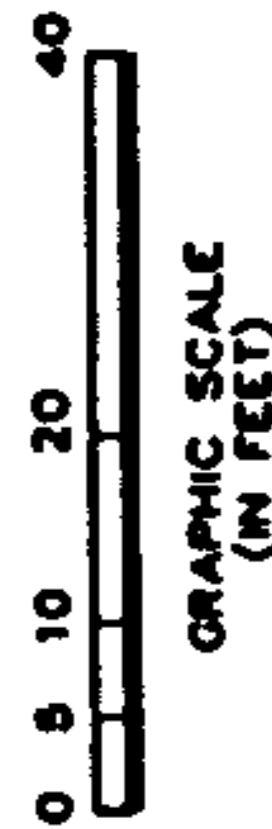

TYPICAL SECTION A-A

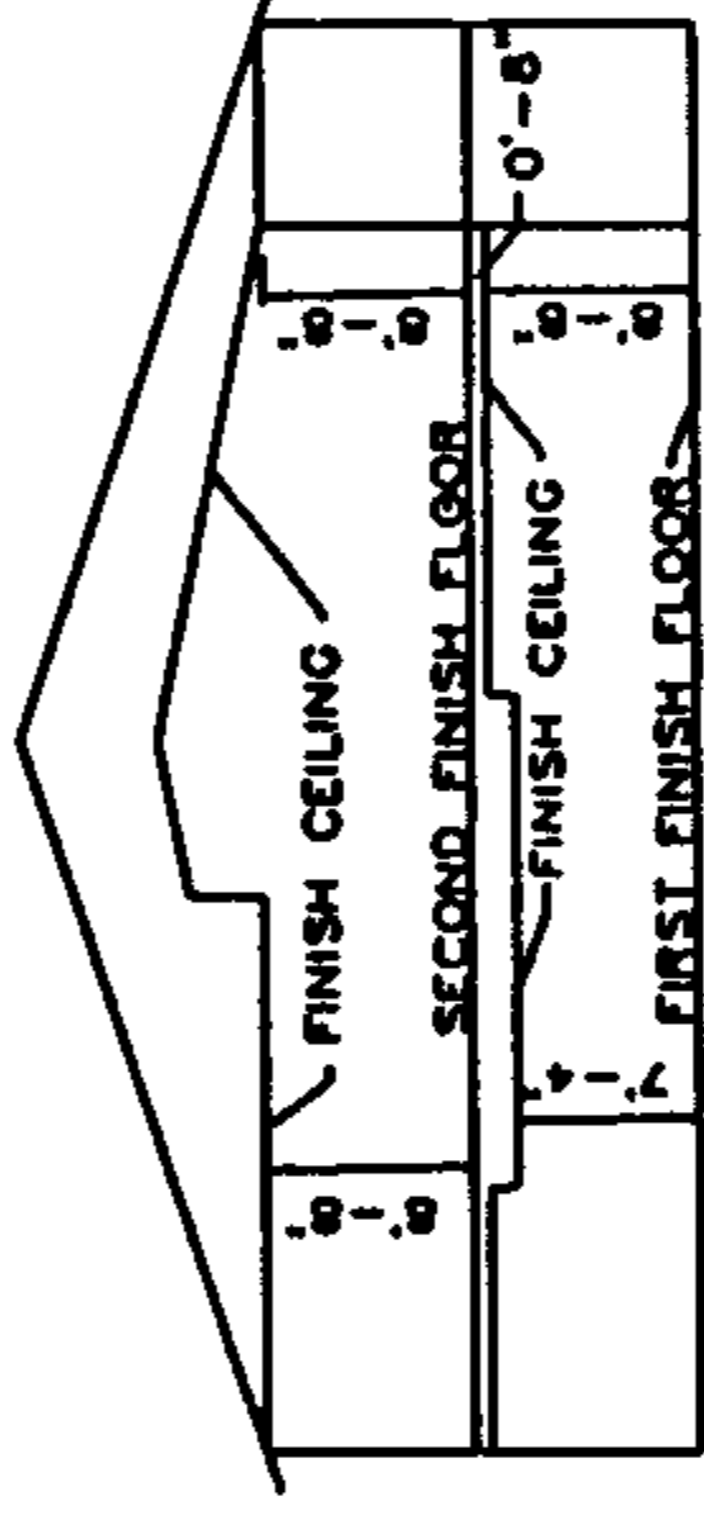

TYPICAL SECTION C-C

TYPICAL ELEVATIONS BUILDING 27
(N.T.S.)

UNIT DESCRIPTION

A unit shall consist of the space bounded within the horizontal planes of the top unfinished surface of the floor structure to the top side of the ceiling drywall and the vertical plane of the backside of the drywall on the exterior walls and boundaries as shown hereon. Unit construction of a particular building is substantially completed, the respective unit in such building shall occupy the air space bounded by the planes as located and dimensioned herein with out reference to the physical improvements described above.

LEGEND

- C = CARPORT
- U = UTILITY ROOM
- B = BALCONY
- N.T.S. = NOT TO SCALE

NOTES: All unit dimensions refer to inside dimensions of the unit and are subject of slight variances which may occur during construction.

Shayer Surveying & Mapping, Inc.
703 SHIMMOCK BALLEWAY
VENICE, FLORIDA 33593
(917) 488-5488 FAX (917) 497-8188
E-MAIL ADDRESS: shayer@shayermapping.com



EXHIBIT "B"

INSTRUMENT # 2004193126
40 PGS



Department of State

I certify the attached is a true and correct copy of the Articles of Incorporation of SOUTH PRESERVE I AT WATERSIDE VILLAGE ASSOCIATION, INC., a Florida corporation, filed on January 28, 2004, as shown by the records of this office.

I further certify the document was electronically received under FAX audit number H04000020422. This certificate is issued in accordance with section 15.16, Florida Statutes, and authenticated by the code noted below.

The document number of this corporation is N04000001004.

Authentication Code: 504A00006875-020204-N04000001004-1/1

Given under my hand and the
Great Seal of the State of Florida,
at Tallahassee, the Capital, this the
Second day of February, 2004



Glenda E. Hood
Glenda E. Hood
Secretary of State

ARTICLES OF INCORPORATION
of
SOUTH PRESERVE I AT WATERSIDE VILLAGE ASSOCIATION, INC.

We, the undersigned, hereby associate ourselves together for the purpose of becoming a corporation not for profit under the laws of the State of Florida, by and under the provisions of the statutes of the State of Florida, providing for the formation, liability, rights, privileges and immunities of a corporation not for profit.

ARTICLE I.
NAME OF CORPORATION

The name of this corporation shall be SOUTH PRESERVE I AT WATERSIDE VILLAGE ASSOCIATION, INC., hereinafter referred to as the Association. The principal office and mailing address shall be 722 Shamrock Boulevard, Venice, Florida 34293.

ARTICLE II.
GENERAL NATURE OF BUSINESS

The general nature of the business to be conducted by the Association shall be the operation and management of the affairs and property of the condominium known as SOUTH PRESERVE I AT WATERSIDE VILLAGE located on Sunset Lake Boulevard, in Sarasota County, Florida, and to perform all acts provided in the Declaration of Condominium of said condominium and in the Florida Condominium Act, Chapter 718, Florida Statutes.

ARTICLE III.
POWERS

The Association shall have all of the condominium law and statutory powers of a corporation not for profit and all of the powers and duties set forth in the Florida Condominium Act and the Declaration of Condominium of said condominium; provided, however, that it shall take a three-fourths vote of all members to authorize the filing of any litigation brought on behalf of the Association other than suits to enforce collection or lien rights for assessments or payables. Provided-, that regarding a proposed suit against the Developer, the three-fourths vote shall be of all non-Developer units only. In the event property adjacent to said condominium is developed as one or more condominiums whose respective declarations of condominium designate the Association as the entity responsible for their operation and maintenance, the Association may accept such responsibility for any or all of such condominiums by affirmative action of the board of directors, which shall be evidenced by a written joinder to each such declaration executed by the Association president. Upon the recording of such joinder, the Association shall assume all of the applicable powers and duties set forth in the declaration. The Association may enter into lease agreements and may acquire and enter into agreements acquiring leasehold, membership and other possessory or use interests for terms up to and including 99 years (whether or not such interests relate to property contiguous to the lands of a condominium operated by the Association) intended to provide for the enjoyment, recreation, or other use or benefit of the Association members, including but not limited to the lease of recreation areas and facilities. The Association shall be authorized to and charged with the responsibility to operate and maintain the common elements, including the stormwater management system and facilities, including detention and retention areas, littoral areas, flow control structures, culverts and related appurtenances.

ARTICLE IV.
MEMBERS

All persons owning a vested present interest in the fee title to a condominium unit in SOUTH PRESERVE I AT WATERSIDE VILLAGE, a condominium, or in any other condominium operated by the Association, which interest is evidenced by a duly recorded proper

instrument in the Public Records of Sarasota County, Florida, shall be members. Membership shall terminate automatically and immediately as a member's vested interest in the fee title terminates, except that upon the termination of a condominium operated by the Association, the membership of a unit owner who conveys his unit to the trustee as provided in the applicable declaration of condominium shall continue until the trustee makes a final distribution of such unit's share of the funds collected and held by the trustee. In the event a unit is owned by a legal entity other than a natural person, the officer, director, or other official so designated by such legal entity shall exercise its membership rights.

After the Association approves of a conveyance of a condominium unit as provided in the applicable declaration of condominium, the change of membership in the Association shall be evidenced in the Association records by delivery to the Association of a copy of the recorded deed or other instrument of conveyance.

Prior to the recording of the Declaration of Condominium of SOUTH PRESERVE I AT WATERSIDE VILLAGE, the subscribers hereto shall constitute the members of the Association and shall each be entitled to one vote.

ARTICLE V. VOTING RIGHTS

Each condominium unit shall be entitled to one vote at Association meetings, notwithstanding that the same owner may own more than one unit or that units may be joined together and occupied by one owner.

ARTICLE VI. INCOME DISTRIBUTION

No part of the income of the Association shall be distributable to its members, except as compensation for services rendered.

ARTICLE VII. EXISTENCE

The Association shall exist perpetually unless dissolved according to law.

ARTICLE VIII. REGISTERED OFFICE AND REGISTERED AGENT

The registered office of the Association shall be at 722 Shamrock Boulevard, Venice, FL 34293, and the registered agent at such address shall be Stephen E. Lattmann until such time as another registered agent is appointed by resolution of the board of directors.

ARTICLE IX. NUMBER OF DIRECTORS

The business of the Association shall be conducted by a board of directors. The initial board of directors shall consist of three (3) persons. Thereafter the number of directors shall be determined by resolution of the membership of the Association, but shall not be less than three (3) persons.

ARTICLE X. FIRST BOARD OF DIRECTORS AND OFFICERS

The names and post office addresses of the members of the first board of directors and officers are as follows:

<u>Name</u>	<u>Address</u>
Stephen E. Lattmann President and Director	722 Shamrock Boulevard Venice, FL 34293
Pamela B. Sullivan Secretary, Treasurer & Director	722 Shamrock Boulevard Venice, FL 34293
Richard Brady Vice President & Director	315 Pine Glen Way Englewood, FL 34223

The method of election of directors of the Association shall be in a manner as set forth in the Bylaws and subsequent officers shall be elected at the annual meeting by the board of directors.

ARTICLE XI.
INDEMNIFICATION OF OFFICERS AND DIRECTORS

All officers and directors shall be indemnified by the Association against all expenses, liabilities, and attorney's fees (including attorney's fees for appellate proceedings) reasonably incurred in connection with any proceeding or settlement thereof in which they may become involved by reason of holding such office. In no event, however, shall any officer or director be indemnified for his own willful misconduct or knowing violation of the provisions of the Florida Condominium Act. The Association may purchase and maintain insurance on behalf of all officers and directors against any liability asserted against them or incurred by them in their capacity as officers and directors or arising out of their status as such.

ARTICLE XII.
RIGHTS OF DEVELOPER

WATERSIDE PRESERVE., INC., a Florida corporation, which is the developer of SOUTH PRESERVE I AT WATERSIDE VILLAGE, a condominium, and which is referred to herein as the Developer, shall have the right to appoint all of the directors of the Association (which directors need not be unit owners), subject to the following:

A. When 15 percent or more of the units in a condominium that will be operated ultimately by the Association are conveyed to owners other than the Developer, such unit owners shall be entitled to elect not less than one-third of the directors.

B. Unit owners other than the Developer are entitled to elect not less than a majority of the Board of Directors upon the first of the following to occur: (i) within three (3) years after fifty percent (50%) or within three (3) months after ninety percent (90%) of the units that will be represented ultimately by the Association are conveyed to owners other than Developer; (ii) when all the units that will be operated ultimately by the Association have been completed, some of them have been conveyed to purchasers, and none of the others are being offered for sale by the developer in the ordinary course of business; (iii) when some of the units have been conveyed to purchasers and none of the others are being constructed or offered for sale by the developer in the ordinary course of business; or (iv) seven years after initial recordation of the declaration of condominium creating the initial phase.

C. When the Developer no longer holds for sale in the ordinary course of business at least five percent (5%) of the units that will be operated ultimately by the Association, unit owners other than the Developer shall be entitled to elect all of the directors.

Any director appointed by the Developer may be removed and replaced by the Developer at any time, subject only to the foregoing rights of the unit owners.

ARTICLE XIII.
BYLAWS

INSTRUMENT # 2004193126
40 PGS

The first bylaws of the Association shall be adopted by the board of directors and may be altered, amended or rescinded in the manner provided in such bylaws by majority vote of the voting rights of the members.

ARTICLE XIV.
SUBSCRIBERS

The name and street address of the subscriber to these Articles of Incorporation is as follows: Stephen E. Lattmann, 722 Shamrock Boulevard, Venice, FL 34293

ARTICLE XV.
AMENDMENTS

The Association reserves the right to amend, alter, change or repeal any provisions contained in these Articles of Incorporation by a simple majority vote of all voting rights of all members of the Association; provided, however, as long as the Developer holds for sale in the ordinary course of business units in any condominium operated by the Association, no amendment which might adversely affect the sale of units shall be effective without the written consent of the Developer.

ARTICLE XVI.
THE FLORIDA CONDOMINIUM ACT

In the event of a conflict between the provisions of these Articles of Incorporation and the Florida Condominium Act, the terms and provisions of the Florida Condominium Act shall control and, to that extent, are incorporated by reference herein. As used in this Article, the "Florida Condominium Act" shall mean the provisions of Chapter 718, Florida Statutes, in effect as of the date on which these Articles of Incorporation are filed by the Florida Secretary of State.

IN WITNESS WHEREOF, we, the undersigned subscribers to these Articles of Incorporation, have hereunto set our hands and seals this 27th day of January 2004.

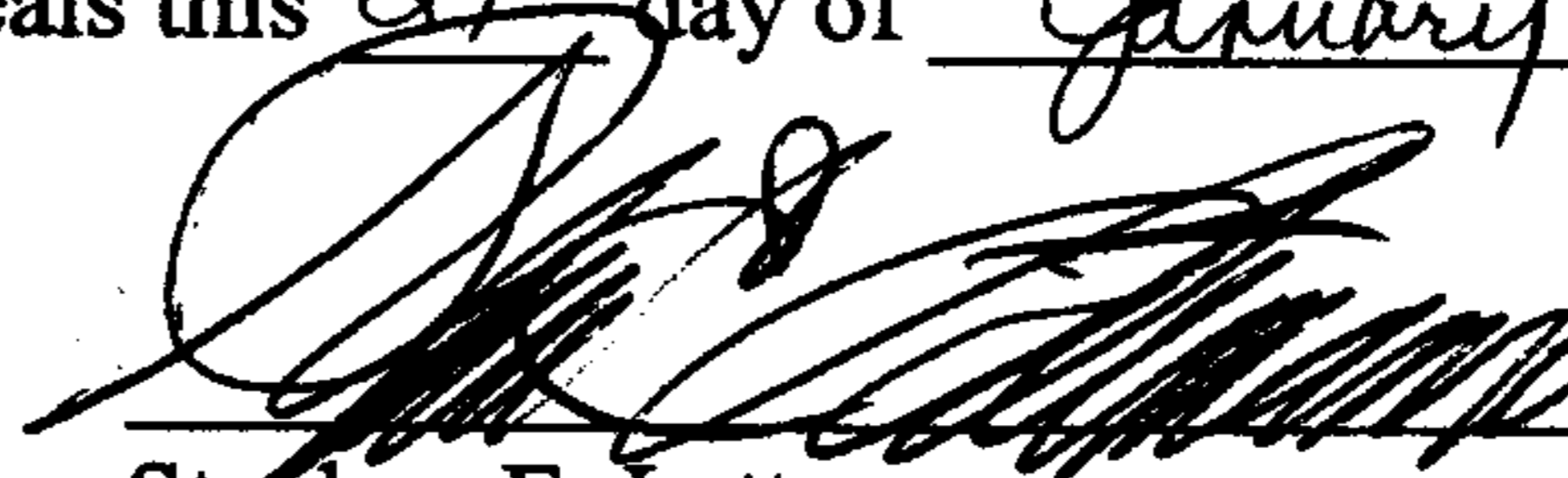

Stephen E. Lattmann
INCORPORATOR

STATE OF FLORIDA
COUNTY OF SARASOTA

The foregoing instrument was acknowledged before me this 27th day of January, 2004 by Stephen E. Lattmann, who is personally known to me or who has produced _____ as identification and who did not take an oath. If no type of identification is indicated, the above-named person is personally known to me.



Signature of Notary Public

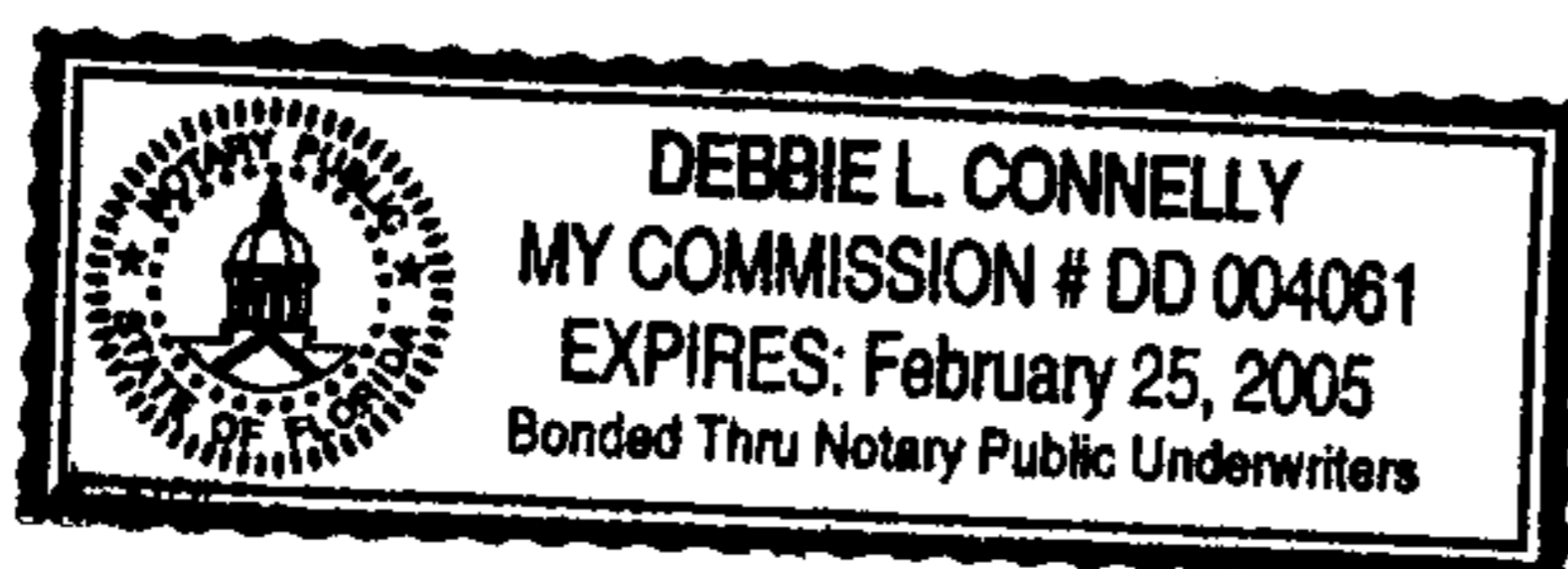

(Notary Seal)

Print Name of Notary Public

I am a Notary Public of the State of Florida,
and my commission expires on _____

H04000020422 3

INSTRUMENT # 2004193126
40 PGS

ACCEPTANCE BY REGISTERED AGENT

The undersigned hereby accepts the designation as registered agent of the foregoing corporation.

Stephen E. Lattmann
Registered Agent

WMS/cw-495603

H04000020422 3

BYLAWS
of
SOUTH PRESERVE I AT WATERSIDE VILLAGE ASSOCIATION, INC.

A corporation not for profit
existing under the laws
of the State of Florida

I. PRINCIPAL OFFICE

The principal office of the Association shall be located at 722 Shamrock Boulevard, Venice, FL 34293. The address of the principal office may be changed at the discretion of the board of directors.

II. MEMBERSHIP

1. **MEMBERS.** All persons owning a vested present interest in the fee title to a condominium unit in SOUTH PRESERVE I AT WATERSIDE VILLAGE, a condominium, which interest is evidenced by a duly recorded proper instrument in the Public Records of Sarasota County, Florida, shall automatically be members of this Association; their membership shall automatically terminate as their vested interest in the fee title terminates. Such membership may, at the discretion of the board of directors, be evidenced by the issuance of a membership certificate which shall be deemed automatically canceled when the membership it evidences is terminated as provided herein.

2. **VOTING RIGHTS.** Each condominium unit shall be entitled to one vote at Association meetings and shall have such voting rights as are provided in the articles of incorporation and the declaration of condominium applicable to such unit. Any vote may be cast in person or by proxy executed in writing and filed with the secretary. If a condominium unit is owned jointly by more than one person or entity, the vote to which the unit is entitled may be cast by any of the joint owners; provided, however, that if more than one of the joint owners cast the vote to which their unit is entitled, said vote shall be apportioned equally among such of the joint owners as cast the vote.

3. **ANNUAL MEETING.** An annual meeting of the members shall be held in December of each year at such time and place as may be designated by the board of directors for the purpose of electing directors and for the transaction of such other business as may come before the meeting.

4. **SPECIAL MEETINGS.** Special meetings may be called by the president or by the board of directors, or by the written request of at least ten percent (10%) of the voting rights of the members, for any purpose and at any time.

5. **NOTICES.** Notice of any meeting of members shall be posted in a conspicuous place on the condominium property and shall be mailed or delivered by an officer of the Association at least 14 days before such meeting to each member at his address as shown in the Association records. The notice shall be posted in a conspicuous place on the condominium property at least fourteen continuous days preceding the annual meeting, and which notice shall incorporate an identification of agenda items. Members may waive such notice and may act by written agreement without meetings, except in those instances where (i) the Association action to be taken or purpose to be served cannot be accomplished without an actual meeting, or (ii) the waiver would be prohibited by applicable law. An officer of the Association, or the manager or other person providing notice of the meeting of directors or of the members, shall provide an affidavit or United States Postal Service certificate of mailing, to be included in the official records of the Association affirming that the notice of meeting was mailed or hand delivered, in accordance with this provision, to each unit owner at the address last furnished to the Association.

6. **QUORUM.** Thirty percent of the voting rights represented in person or by proxy shall constitute a quorum, and if a quorum is not present, a majority of the voting rights present may adjourn the meeting from time to time. A simple majority of all voting rights present in person or otherwise represented shall decide any question brought before the meeting, except when otherwise required by the Florida Condominium Act, the declaration of condominium, the articles of incorporation, or these bylaws.

III. BOARD OF DIRECTORS

1. **POWERS.** The board of directors shall have all powers necessary to manage the affairs of the Association and to discharge its rights, duties, and responsibilities as provided in the Florida Condominium Act, the declaration of condominium, the articles of incorporation, and these bylaws. The board on behalf of the Association shall have the power to levy fines in accordance with the provisions of Section 718.303(3).

2. **NUMBER.** The number of directors shall be determined by resolution of the membership from time to time, but in no event shall be less than three directors.

3. **QUALIFICATION.** Each director shall be a member, or a spouse, parent, or adult child of a member, of the Association or a person exercising the rights of an owner who is not a natural person, except that any director appointed by the Developer need not be a member of the Association. All directors shall act without compensation unless otherwise provided by resolution of the membership of the Association.

4. **ELECTION AND TERM.** Except as hereinafter provided, the term of each director shall expire upon the election of his successor at the next succeeding annual meeting of members. Commencing with the first annual meeting of members at which unit owners other than the Developer elect a majority of the board of directors, a majority of the directors receiving the highest number of votes shall serve two-year terms, and the other elected directors shall serve one-year terms. Thereafter, directors shall be elected for two-year terms to fill the vacancies of those directors whose terms are then expiring. All directors shall serve until their respective successors shall have been duly elected and qualified, or until their earlier resignation or removal. Board member elections shall be conducted pursuant to Section 718.112(2)(d)2, and Rule 61B-23.0021, Florida Administrative Code.

5. **REGULAR MEETINGS.** An annual meeting of the board of directors shall be held immediately after, and at the same place as, the annual meeting of the membership. Additional regular meetings may be held as provided by resolution of the board.

6. **SPECIAL MEETINGS.** Special meetings of the board may be called by the president or a majority of the directors for any purpose and at any time or place.

7. **NOTICES.** Notice of any meeting of the board, except an emergency meeting, shall be mailed or delivered to each director at his address shown in the Association records at least five days before such meeting, unless notice is waived by such director. Notices of special meetings shall state the purpose thereof. Notice of any meeting of the board, except an emergency meeting, shall be posted conspicuously on the condominium property at least 48 continuous hours in advance of the meeting. Any item not included on the notice may be taken up on an emergency basis by at least a majority plus one of the members of the Board. Such emergency action shall be noticed and ratified at the next regular meeting of the Board. All meetings of the board shall be open to the members. However, written notice of any meeting at which nonemergency special assessments, or at which amendments to rules regarding unit use, will be considered, shall be mailed or delivered to unit owners and posted conspicuously on the condominium property at least fourteen (14) days prior to the meeting. Upon notice to unit owners, the board shall designate a specific location on the condominium property or association property upon which notices of board meetings and unit owners meetings can be posted.

8. **QUORUM.** A majority of directors shall constitute a quorum. If a quorum is not present, a majority of those present may adjourn the meeting from time to time. The vote of a majority of directors present shall decide any matter before the board, except as may be

otherwise required by the articles of incorporation, these bylaws, or the declaration of condominium.

9. **REMOVAL.** Any director appointed by the Developer may be removed by the Developer at any time by giving written notice to the board of directors, and the vacancy created by such removal shall be filled by appointment by the Developer. The removal of any director elected by the members shall be subject to the provisions of Section 718.112(2)(j), Florida Statutes.

10. **CERTIFICATE OF COMPLIANCE.** A certificate of compliance from a licensed electrical contractor or electrician may be accepted by the board of directors as evidence of compliance of the condominium units to the applicable fire and life safety code.

11. **LIMITED POWER TO CONVEY.** The Association, by vote of its board of directors, shall have a limited power to convey a portion of the common elements to a condemning authority for the purpose of providing utility easements, right of way expansion, or other public purposes, whether negotiated or as a result of eminent domain proceedings.

IV. OFFICERS

1. **NUMBER.** The officers shall be a president, a vice president, a secretary, and a treasurer, each of whom shall be elected by the board of directors. Such assistant officers as may be deemed necessary may be elected by the board of directors. The officers need not be members of the Association. All officers shall act without compensation unless otherwise provided by resolution of the membership.

2. **ELECTION AND TERM.** Each officer shall be elected annually by the board of directors at the first meeting of directors following the annual meeting of members and shall hold office until his successor shall have been elected and duly qualified, or until his earlier resignation or removal.

3. **PRESIDENT.** The president shall be the principal executive officer of the Association and shall supervise all of the affairs of the Association. He shall preside at all meetings of members and directors. He shall sign all agreements and recordable instruments on behalf of the Association, unless otherwise provided by resolution of the board of directors.

4. **VICE PRESIDENT.** In the absence of the president, the vice president shall perform the duties of the president, and when so acting, shall have all the powers and responsibilities of the president. The vice president shall also perform such duties as may be designated by the board of directors.

5. **SECRETARY.** The secretary may attest to any agreement or recordable instrument on behalf of the Association, but such attestation shall not be required. The secretary shall record the minutes of meetings of members and directors. The secretary shall have the primary responsibility, but not the exclusive right, to give notices required by these bylaws. He shall have custody of and maintain the records of the Association, other than those maintained by the treasurer. The board of directors may elect an assistant secretary, who shall perform the duties of the secretary when the secretary is absent.

6. **TREASURER.** The treasurer shall have custody of all funds of the Association, shall deposit the same in such depositories as may be selected by the board of directors, shall disburse the same, and shall maintain the Association's financial records, which shall be available for inspection by any member during business hours on any weekday. At the discretion of the board of directors, the functions of the treasurer may be delegated to and performed by a managing agent or financial institution located in Sarasota County.

7. **FIDELITY BONDS.** All officers, directors and other persons who control or disburse funds of the Association shall be bonded by a surety company selected by the board in an amount determined by the board to be sufficient to insure the proper handling of all cash funds and other corporate assets (but not less than required by Chapter 718 Florida Statutes). The cost of such bond shall be paid by the Association.

8. **REMOVAL.** Any officer may be removed by a majority vote of the board of directors present at any meeting of the board, and the vacancy thereby created shall be filled by an election by the board of directors.

V. MANAGER AND EMPLOYEES

The board of directors may employ the services of a manager and other employees and agents as they shall determine appropriate to manage, operate, and care for the condominium property, with such powers and duties and at such compensation as the board may deem appropriate and provide by resolution from time to time. Such manager, employees, and agents shall serve at the pleasure of the board.

VI. CONTRACTS AND FINANCES

1. **CONTRACTS.** In addition to the authority granted herein to the president and vice president, the board of directors may authorize any officer or agent to execute and deliver any contract or other instrument on behalf of the Association.

2. **LOANS.** No loans shall be contracted on behalf of the Association and no evidences of indebtedness shall be issued in its name unless authorized by a resolution of the board of directors. The board may authorize a lien to be placed upon any property owned by the Association and the pledge and assignment of proceeds of any regular or special assessment of the Association as security for the repayment of any loan.

3. **CHECKS AND NOTES.** All checks, drafts, and other orders for payment of money issued in the name of the Association shall be signed by the treasurer or such officers or agents of the Association as shall from time to time be authorized by resolution of the board of directors. All promissory notes or other evidences of indebtedness of the Association shall be signed by the president or vice president.

4. **DEPOSITS.** All funds of the Association shall be deposited to the credit of the Association in such banks, savings and loan associations, or other depositories as the board of directors may select from time to time.

5. **FISCAL YEAR.** Unless otherwise established by resolution of the board of directors, the fiscal year of the Association shall be a calendar year.

VII. VACANCIES

When there is a vacancy on the board of directors occurring at a time when both the developer and the unit owners other than the developer are entitled to representation on that board, then the vacancy shall be filled as follows:

(a) Directors elected or appointed by unit owners other than a developer shall be subject to recall only by unit owners other than a developer. Voting interests owned or controlled by a developer shall not vote in such recall. For purposes of establishing a quorum, only units owned by unit owners other than a developer shall be counted.

(b) Directors elected or appointed by developer shall be subject to recall by only that developer. Voting interests owned or controlled by unit owners other than that developer shall not vote in such recall. For purposes of establishing a quorum, only units owned by that developer shall be counted.

(c) Subject to the entitlement to representation provisions of Section 718.301, Florida Statutes, only the developer may vote to fill a vacancy on the board previously occupied by a board member elected or appointed by that developer, in which case a quorum for that purpose shall consist of a majority of units owned by the developer. Only unit owners other than a developer may vote to fill a vacancy on the board previously occupied by a board member

elected or appointed by unit owners other than the developer, in which case a quorum for purposes of that vote shall consist of a majority of unit owners other than the developer.

VIII. AMENDMENTS TO BYLAWS

These bylaws may be altered or repealed by new bylaws adopted by majority vote of the voting rights at the annual meeting or at any special meeting of the members. No modification of or amendment to the bylaws shall be valid unless set forth in or attached to a duly recorded amendment to the declaration of condominium.

IX. REGULATIONS

The board of directors may from time to time adopt such uniform administrative rules and regulations governing and restricting the use and maintenance of the condominium units and common elements and other property owned or operated by the Association as may be deemed necessary and appropriate to prevent unreasonable interference with the use thereof and to assure the enjoyment thereof by the unit owners. Such rules and regulations shall not be inconsistent with the Florida Condominium Act, the declaration of condominium, the articles of incorporation, or these bylaws. A copy of such rules and regulations shall be available at the office of the condominium and shall be distributed to each unit owner, although the failure to furnish a copy thereof in any instance shall not affect the enforceability of any such rule or regulation.

X. SEAL

The board of directors shall provide a corporate seal, circular in form, showing the corporate name, the year and state of incorporation, and the words "corporation not for profit."

XI. COLLECTION OF ASSESSMENTS

The board of directors shall be authorized and responsible to establish and adopt an annual budget. Assessments pursuant thereto for the payment of common expenses shall be levied annually by the board of directors in the manner provided in the declaration of condominium. Assessments shall be payable in advance to the Association on the first day of the first, fourth, seventh, and tenth months of each fiscal year. Special assessments may be levied by the board of directors in the manner provided in the declaration of condominium or the Florida Condominium Act.

XII. ARBITRATION

In the event of a dispute (as defined in Section 718.1255) arising from the operation of the condominium among units owners, the Association, and their agents or assigns, prior to the institution of court litigation, the parties to the dispute shall petition the Division of Florida Land Sales, Condominiums and Mobile Homes for nonbinding arbitration.

XIII. THE FLORIDA CONDOMINIUM ACT

In the event of a conflict between the provisions of these bylaws and the Florida Condominium Act, Chapter 718, Florida Statutes (2002), or in the event the Florida Condominium Act sets forth mandatory bylaws provisions that are not expressly contained herein, the terms and provisions of the Florida Condominium Act shall control and, to that extent, are incorporated by reference herein.